

DOGA

WASHER SYSTEMS

EQUIPOS LAVAPARABRISAS - SISTEMI LAVACRISTALLI - ÉQUIPEMENTS LAVE-GLACE - SCHEIBENWASCHANLAGEN

WASHER PUMPS
ACCESSORIES
CUSTOMIZED & SPECIAL PROJECTS
SPARE PARTS



203

DOGA manufactures a wide range of windshield washer systems and accessories that offer appropriate solutions for each vehicle or machine, providing maximum glass cleaning.

Thanks to the incorporation of new state-of-the-art equipment that meets all Industry 4.0 standards, we have achieved automation and optimization in each of the manufacturing processes, therefore guaranteeing maximum quality in each product.

Our team of engineers works in a multidisciplinary fashion, thus responding in a streamlined manner and effectively to the new technological requirements. Each project follows the most appropriate methodology to meet and exceed the requirements of customers and their industry.

DOGA fabbrica un'ampia gamma di sistemi lavaparabrezza e accessori che offrono soluzioni adeguate a ogni veicolo o macchina per una pulizia dei vetri eccellente.

Grazie all'introduzione di nuove attrezzature con una tecnologia di ultima generazione che rispetta tutti gli standard dell'Industria 4.0, siamo riusciti a ottenere un'automatizzazione e ottimizzazione in ciascuno dei processi di fabbricazione, garantendo la massima qualità in ogni prodotto.

Il nostro team di ingegneri lavora in formato multidisciplinare offrendo in questo modo una risposta agile ed efficace alle nuove esigenze tecnologiche, e ogni progetto segue la metodologia più adeguata per rispettare e superare tutti i requisiti dei clienti e dell'industria.

Chez DOGA, nous fabriquons une vaste gamme de systèmes lave-glaces et d'accessoires qui offrent des solutions appropriées pour chaque véhicule ou machine en fournissant un nettoyage optimal des vitres.

Grâce à l'intégration de nouveaux équipements de dernière technologie qui satisfont toutes les normes de l'Industrie 4.0, nous avons obtenu une automatisation et une optimisation dans chacun des processus de fabrication, en garantissant ainsi une qualité maximale dans chaque produit.

Notre équipe d'ingénieurs travaille d'une façon multidisciplinaire en donnant une réponse rapide et efficace aux nouvelles exigences technologiques. Chaque projet suit la méthodologie la plus appropriée pour satisfaire et dépasser les exigences des clients et de l'industrie.

En DOGA fabricamos una amplia gama de sistemas lavaparabrisas y accesorios que ofrecen soluciones adecuadas para cada vehículo o máquina proporcionando una máxima limpieza de los cristales.

Gracias a la implementación de la nueva tecnología inteligente asociada a la Industria 4.0 hemos logrado automatización y optimización en cada uno de los procesos de fabricación garantizando una máxima calidad en cada producto.

Nuestro equipo de ingenieros trabaja en formato multidisciplinar ofreciendo así una respuesta competencial a las nuevas exigencias tecnológicas. Cada proyecto recibe un trato individualizado y personalizado y se desarrolla aplicando todo el conocimiento que nos aporta este nuevo modelo de industria que ofrece un máximo beneficio a nuestros clientes.



Bei DOGA fertigen wir eine breite Palette von Scheibenwischersystemen und Zubehör, die angemessene Lösungen für alle Fahrzeuge oder Maschinen bieten und eine maximale Reinigung der Scheiben gewährleistet.

Dank der Einführung neuer Anlagen auf dem jüngsten Stand der Technik, die alle Industriestandards 4.0 erfüllen, haben wir jeden unserer Fertigungsprozesse automatisiert und optimiert und bieten so höchste Qualität bei allen Erzeugnissen.

Unser Ingenieursteam arbeitet multidisziplinär und bietet so eine rasche und effektive Reaktion auf neue technologische Ansprüche und für jedes Projekt wird die am besten geeignete Methodologie angewandt, um so die Ansprüche der Kunden und ihrer Industrie zu erfüllen und zu bewältigen.

TECHNOLOGY

WINDSHIELDWASHERSYSTEMS

AUTOMATION

CUSTOMIZED

ACCESSORIES

INDUSTRY40

WASHERPUMPS

QUALITY

MANUFACTURER

ENGINEERING

KNOWHOW

SPECIALPROJECTS

	<p>CAPACITY IN LITERS CAPACIDAD EN LITROS CAPACITÀ IN LITRI CAPACITÉ EN LITRES FÜLLMENGE IN LITERN</p>	
	<p>MATERIAL (PP, PEHD) AND COLOR MATERIAL (PP, PEHD...) Y COLOR MATERIALE (PP, PEHD) E COLORE MATÉRIAU (PP, PEHD) ET COULEUR MATERIAL (PP, PEHD) UND FARBE</p>	
	<p>FABRICATION METHOD: I = INJECTION, S= BLOW MOULDING, R = ROTATIONAL MOULDING SISTEMA DE FABRICADO: I = INYECCIÓN, S= SOPLADO, R = ROTOMOLDEO TECNICA DI FABBRICAZIONE: I = INIEZIONE, S= SOFFIAGGIO, R = ROTAZIONALE SYSTÈME DE FABRICATION: I = INJECTION, S= SOUFLAGE, R = ROTO MOULAGE PRODUKTIONSMETHODE: I= SPRITZGUSS, S= BLASVERFAHREN, R= ROTATION</p>	
	<p>SNAP ON CAP AND DIAMETER TAPÓN A PRESIÓN Y DIÁMETRO TAPPO A PRESSIONE E DIAMETRO BOUCHON A PRESSION ET DIAMETRE SCHNAPPVERSCHLUSS UND DURCHMESSER</p>	
	<p>SCREW CAP AND DIAMETER TAPÓN ROSCADO Y DIÁMETRO TAPPO A VITE E DIAMETRO BOUCHON VISSABLE ET DIAMETRE SCHRAUBVERSCHLUSS UND DURCHMESSER</p>	
	<p>CAP WITH ANTI-REFLUX TAPÓN CON ANTIRREFLUJO TAPPO CON ANTIRIFLUSSO BOUCHON AVEC ANTI-REFLUX SCHRAUBVERSCHLUSS MIT ANTI REFLUX</p>	
	<p>TYP PUMP TYP BOMBA TYP ELETTROPOMPA TYP POMPE TYP PUMPE</p>	
	<p>PUMP POSITION IN BOTTLE POSICIÓN BOMBA EN DEPÓSITO POSIZIONE DELL'ELETTROPOMPA NEL SERBATOIO POSITION DE LA POMPE AU RESERVOIR UNTERBRINGUNG DER PUMPE AM BEHÄLTER</p>	
	<p>WITH LEVEL INDICATOR CON INDICADOR DE NIVEL CON INDICATORE DI LIVELLO AVEC INDICATEUR DE NIVEAUX MIT FÜLLSTANDSANZEIGE</p>	
	<p>FILTER INCLUDED INCLUYE FILTRO INCLUDE FILTRO FILTRE INCLUS MIT FILTER</p>	
	<p>SUPPORT INCLUDED INCLUYE SOPORTE INCLUDE STAFFA SUPPORT INCLUS MIT HALTER</p>	
	<p>SUPPORT REQUIRED REQUIERE SOPORTE RICHIEDE STAFFA SUPPORT REQUIS HALTER ERFORDERLICH</p>	

06**QUICK GUIDE**

6 complete parts numbers
7 washer tanks

GUÍA RÁPIDA
GUIA RAPIDA
GUIDE RAPIDE
MODELLÜBERBLICK

11**WASHER SYSTEMS**

EQUIPOS LAVAPARABRISAS
SISTEMI LAVACRISTALLI
ÉQUIPEMENTS LAVE-GLACE
SCHEIBENWASCHANLAGEN

32**WASHER PUMPS**

BOMBAS
ELETTROPOMPE
POMPES
PUMPEN

34**ACCESSORIES**

45 mounting diagram

ACCESORIOS
ACCESSORI
ACCESSOIRES
ZUBEHÖR

46**CUSTOMIZED & SPECIAL PROJECTS**

PROYECTOS ÚNICOS
PROGETTI UNICI
PROJETS UNIQUES
EINZIGARTIGE PROJEKTE

48**OPTIONAL CAPS**

TAPONES OPCIONALES
TAPPI OPZIONALI
BOUCHONS OPTIONNELS
OPTIONALE VERSCHLUSSDECKEL

49**SPARE PARTS**

RECAMBIOS
RICAMBI
RECHANGES
ERSATZTEILE

PARTS NUMBERS - REFERENCIAS - CODICI - RÉFÉRENCES - REFERENZNUMMERN

FOR STANDARD WASHER SYSTEMS **ORDERS**, PLEASE, COMPLETE PART NUMBER WITH ALL OPTIONS

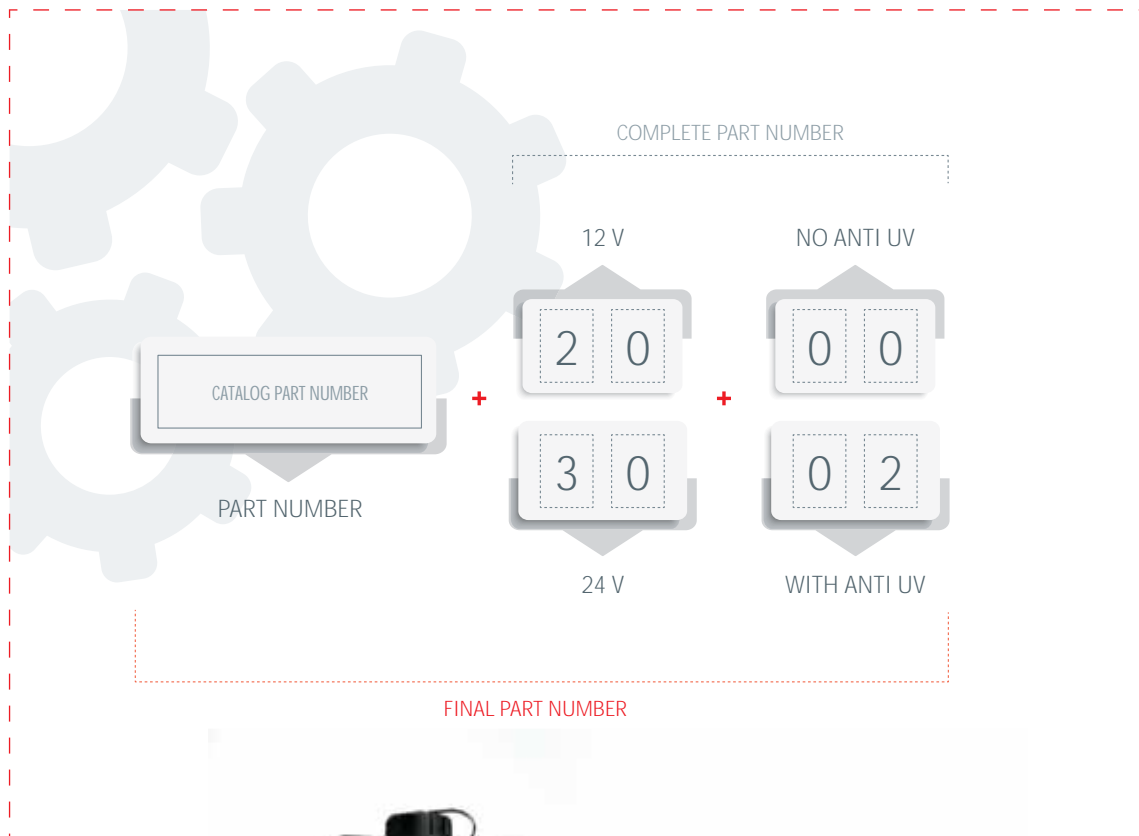

CAPACITY	TYP	NUMBER	V								
1L	D2	1-2	12-24	-	●		-	-	-	●	▶
1.1L	D2	1	12	-	●		-	-	-	-	▶
1.2L	G1	1	12-24	●	-		●/-	-	-	-	
	H3	1	12-24	●	-		-	-	-	-	
	GS	1	12-24	●	-		●/-	-	-	-	▶
	H3/D2	2	12-24	●	-		-	-	-	-	
	G1	1-2	12-24	-	●		●/-	●	-	-	
	H3/D2	2	12-24	-	●		●	●	-	-	▶
1.5L	D2	1-2	12-24	-	●		-	-	-	●	▶
	H3	1	12-24	-	●		-	-	-	●	
	D2	1	12-24	-	●		-	●	-	●	▶
	D2	1	12-24	-	●		-	-	-	-	▶
1.5L	E1	1	12/24	-	●		-	-	-	●	▶
	F1	1	12/24	-	●		-	-	-	●	▶
1.75L	D2	1-2	12-24	-	●		-	-	-	●	▶
	D2	1-2	12	-	●		-	-	-	●	▶
2.1L	G1	1-2	12-24	●	-		●/-	-	-	-	
	GS	1-2	12-24	●	-		●/-	-	-	-	▶
	H3	1	12-24	●	-		●/-	-	-	-	

CAPACITY	TYP	NUMBER	V			COLOR				
----------	-----	--------	---	--	--	-------	--	--	--	--

2.1L

G1	1-2	12-24	-	●		●/-	●	-	-
H3	1	12-24	-	●		-	●	-	-
GS	1-2	12-24	-	●		●/-	●	-	-

2.2L

D2	1-2	12-24	-	●		-	-	-	●
D2	3	12-24	-	●		-	-	-	●

2.5L

D2	1	12-24	-	●		-	-	-	-
----	---	-------	---	---	--	---	---	---	---

3L

G1	1	12-24	●	-		●/-	-	-	-
GS	1	12-24	●	-		●/-	-	-	-
H3	1	12-24	●	-		-	-	-	-
HS	1	12-24	●	-		-	-	-	-

G1	1	12-24	●	-		●/-	-	-	-
GS	1	12-24	●	-		●/-	-	-	-
H3	1	12-24	●	-		-	-	-	-
HS	1	12-24	●	-		-	-	-	-

G1	1	12-24	-	●		●/-	●	-	-
GS	1	12-24	-	●		●/-	●	-	-
H3	1	12-24	-	●		●/-	●	-	-
HS	1	12-24	-	●		●/-	●	-	-

G1	1	12-24	-	●		●/-	●	-	-
GS	1	12-24	-	●		●/-	●	-	-
H3	1	12-24	-	●		-	●	-	-
HS	1	12-24	-	●		-	●	-	-

D2	1	12-24	-	●		-	-	-	●
D2	2	12-24	-	●		-	-	-	●



CAPACITY	TYP	NUMBER	V							
----------	-----	--------	---	--	--	--	--	--	--	--

3.2L

D2	1	12-24	-			-	-	-	
D2	2-3-4	12-24	-			-	-	-	

3.5L

D2	1-2	12-24	-			-	-	-	
D2	1	12-24	-			-	-	-	

4L

G1	1	12-24	-			-		-	-
GS	1	12-24	-			-		-	-

5L

D2	3	24	-			-	-	-	-
D2	1-2	12-24	-			-	-	-	-
D2	3	12-24	-			-	-	-	-

5.3L

G1	1-2	12-24		-			-	-	-
G1	3	12-24		-		-	-	-	-
GS	1-2-3	12-24		-			-	-	-
H3	1-2	12-24		-			-	-	-
G1	1-2	12-24	-					-	-
G1	3	12-24	-			-		-	-
GS	1-2-3	12-24	-					-	-
H3	1-2	12-24	-					-	-

5.8L

G1	1	12-24	-					-	-
G1	2	12-24	-					-	-
GS	1	12-24	-					-	-
GS	2	12-24	-					-	-
G1	1	12-24	-					-	-
GS	1	12-24	-					-	-



CAPACITY	TYP	NUMBER	V								
----------	-----	--------	---	--	--	--	--	--	--	--	--

7L

F1	1	12-24	-			-	-	-	-	-
----	---	-------	---	--	--	---	---	---	---	---



8.7L

G1	1-2	24	-			-		-	-	-
----	-----	----	---	--	--	---	--	---	---	---



GS	1-2	24	-					-	-	-
----	-----	----	---	--	--	--	--	---	---	---



G1	2	24	-						-	-
----	---	----	---	--	--	--	--	--	---	---



GS	2	24	-					-	-	-
----	---	----	---	--	--	--	--	---	---	---



9.7L

G1	1-2	12-24		-			-	-	-	-
----	-----	-------	--	---	--	--	---	---	---	---



G1	3	12-24		-		-	-	-	-	-
----	---	-------	--	---	--	---	---	---	---	---

GS	1-2-3	12-24		-			-	-	-	-
----	-------	-------	--	---	--	--	---	---	---	---

H3	1	12-24		-			-	-	-	-
----	---	-------	--	---	--	--	---	---	---	---

G1	1-2	12-24	-				-	-	-	-
----	-----	-------	---	--	--	--	---	---	---	---

G1	3	12-24	-			-		-	-	-
----	---	-------	---	--	--	---	--	---	---	---



GS	1-2-3	12-24	-				-	-	-	-
----	-------	-------	---	--	--	--	---	---	---	---

11.6L

GS	2	12-24	-				-	-	-	-
----	---	-------	---	--	--	--	---	---	---	---



15L

G1	1-2	12-24		-			-	-	-	-
----	-----	-------	--	---	--	--	---	---	---	---



GS	1-2	12-24		-			-	-	-	-
----	-----	-------	--	---	--	--	---	---	---	---

G1	1-2	12-24	-				-	-	-	-
----	-----	-------	---	--	--	--	---	---	---	---



GS	1-2	12-24	-				-	-	-	-
----	-----	-------	---	--	--	--	---	---	---	---



19.4L

G1	2	24		-			-	-	-	-
----	---	----	--	---	--	--	---	---	---	---



G1	2	24	-					-	-	-
----	---	----	---	--	--	--	--	---	---	---



GS	2	24	-				-	-	-	-
----	---	----	---	--	--	--	---	---	---	---



20L

G4	1-2	24	-			-	-	-	-	-
----	-----	----	---	--	--	---	---	---	---	---



1 L

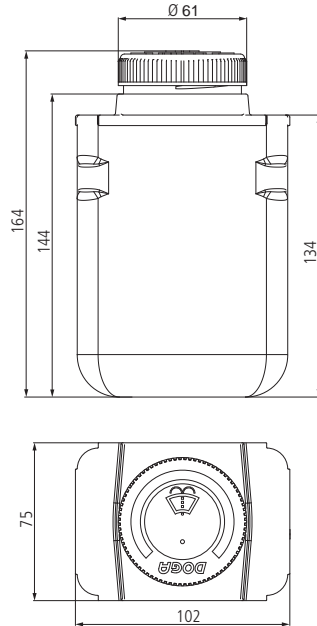

TYP	NUM.	V			PART NUMBER
D2	1	12/24	A	-	2311013
D2	1	12	C	-	2311030
D2	1	12	D	-	2311096
D2	2	12/24	B	-	2312019

FOR COMPLETE PART NUMBER SEE PAGE 6

1.1 L

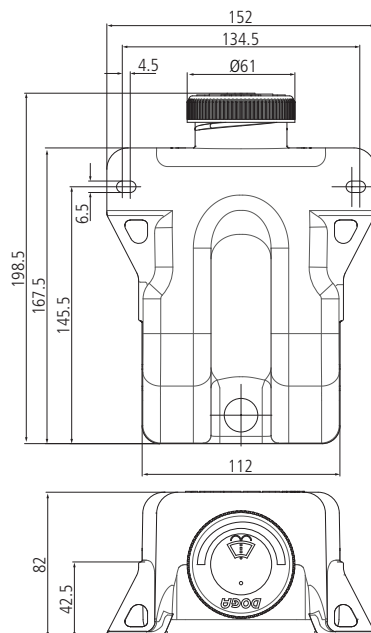

TYP	NUM.	V			PART NUMBER
D2	1	12	A	-	2311076

FOR COMPLETE PART NUMBER SEE PAGE 6

1.2 L



23000123900

ANTI U.V.
OPTIONAL

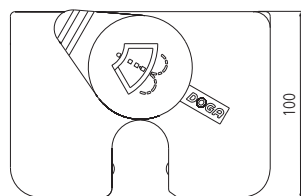
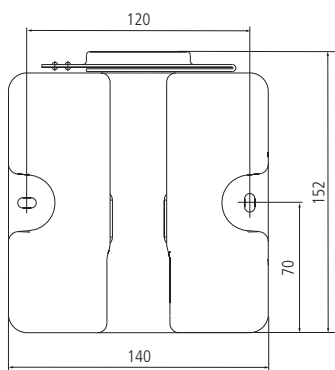

TYP	NUM.	V			PART NUMBER
G1	1	12/24	A	-	2311094
G1	1	12/24	A	•	2311074
H3	1	12/24	A	-	2311080
GS	1	12/24	A	-	2311104
GS	1	12/24	A	•	2311105
H3/D2	2	12/24	B	-	2312036

FOR COMPLETE PART NUMBER SEE PAGE 6

1.2 L



23050243900

ANTI U.V.
OPTIONAL

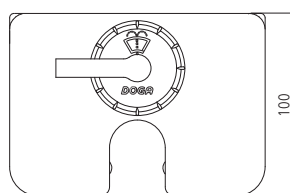
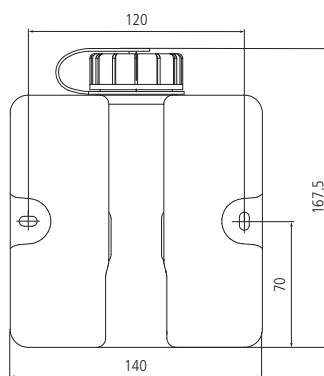

TYP	NUM.	V			PART NUMBER
G1	1	12/24	A	-	2311098
G1	1	12/24	A	•	2311091
GS	1	12/24	A	-	2311102
GS	1	12/24	A	•	2311103

FOR COMPLETE PART NUMBER SEE PAGE 6

1.5 L

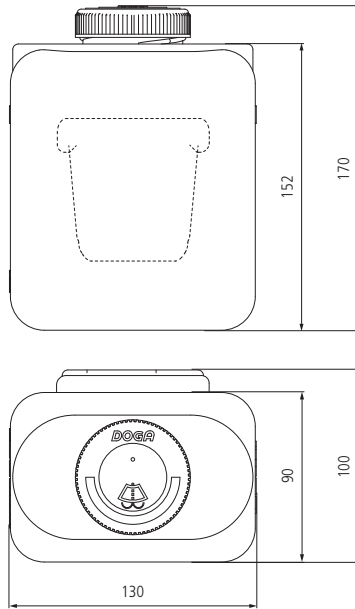
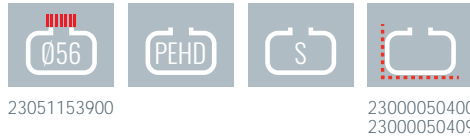

TYP	NUM.	V			PART NUMBER
D2	1	12	A	-	2311005
D2	1	24	A	-	2311024
D2	1	12/24	E	-	2311053
D2	1	12/24	C	-	2311081
H3	1	12	A	-	2311075
D2	2	12/24	B	-	2312002
D2	2	12/24	D	-	2312008

FOR COMPLETE PART NUMBER SEE PAGE 6

1.5 L

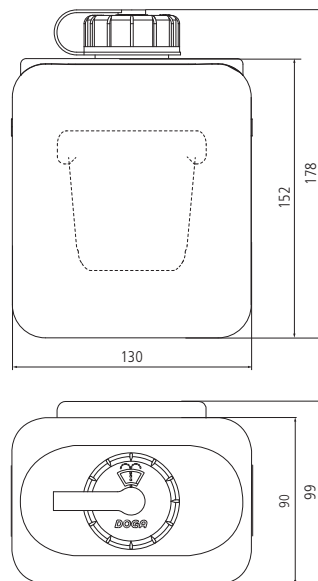

TYP	NUM.	V			PART NUMBER
D2	1	12/24	A	-	2311057

FOR COMPLETE PART NUMBER SEE PAGE 6

1.5 L



23051153900

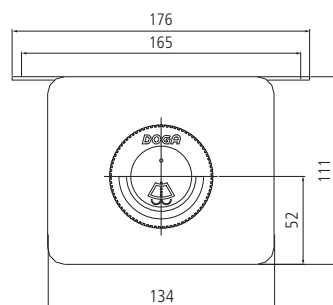
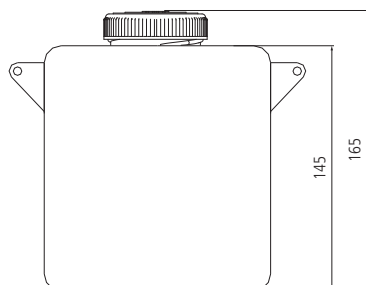

TYP	NUM.	V			PART NUMBER
D2	1	12/24	C	-	2311014
D2	1	12	B	-	2311047
D2	1	12/24	A	-	2311054

FOR COMPLETE PART NUMBER SEE PAGE 6

1.5 L



23051153900

23000090409

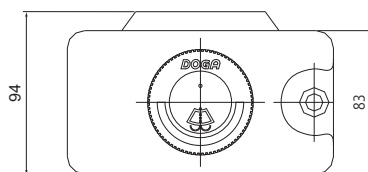
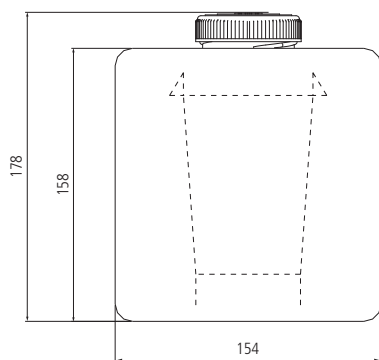

TYP	NUM.	V			PART NUMBER
E1	1	12/24	A	-	2311018
F1	1	12/24	A	-	2311086

FOR COMPLETE PART NUMBER SEE PAGE 6

1.75 L



 23051153900 **ANTI U.V. OPTIONAL** 23000070400
 23000070409

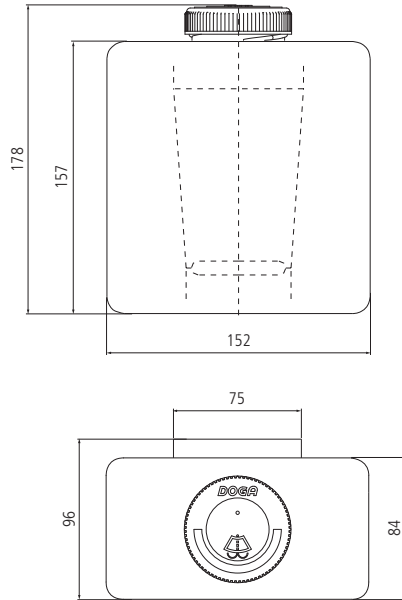

TYP	NUM.	V			PART NUMBER
D2	1	12/24	A	-	2311055
D2	1	12/24	B	-	2311060
D2	2	12/24	D	-	2312010
D2	2	12/24	C	-	2312024
D2	2	12/24	E	-	2312026

FOR COMPLETE PART NUMBER SEE PAGE 6

1.75 L



 23051153900 23000070400
 23000070409

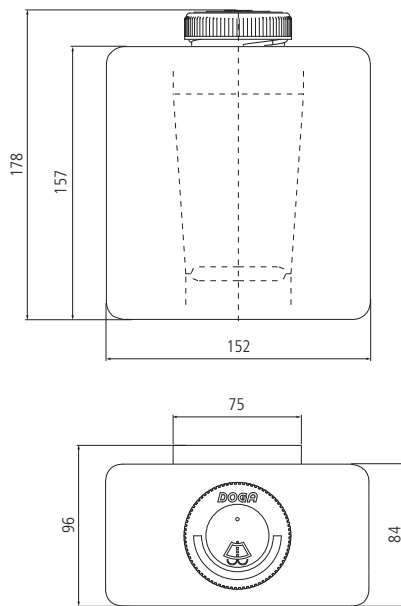

TYP	NUM.	V			PART NUMBER
D2	1	12	A	-	2311011
D2	2	12	B	-	2312005

FOR COMPLETE PART NUMBER SEE PAGE 6

2.1 L

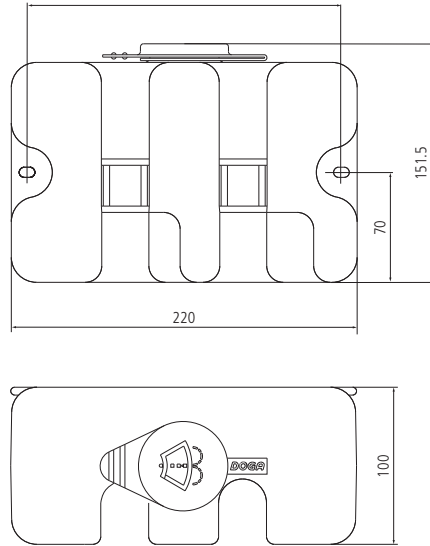
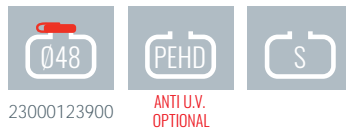

TYP	NUM.	V			PART NUMBER
G1	1	12/24	A	-	2321053
G1	1	12/24	A	●	2321054
H3	1	12/24	A	-	2321071
H3	1	12/24	A	●	2321072
GS	1	12/24	A	-	2321055
GS	1	12/24	A	●	2321056
G1	2	12/24	B	-	2322061
G1	2	12/24	B	●	2322064
GS	2	12/24	B	-	2322065
GS	2	12/24	B	●	2322066

FOR COMPLETE PART NUMBER SEE PAGE 6

2.1 L

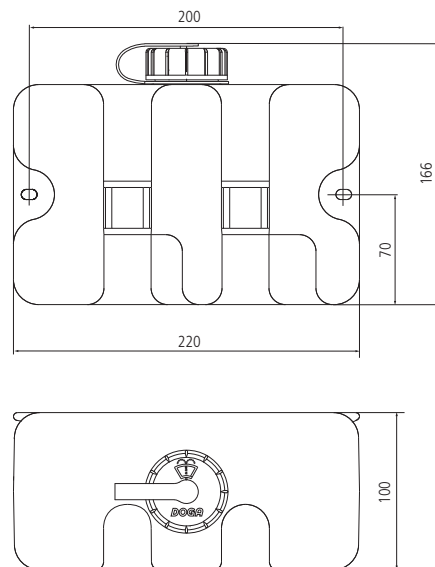
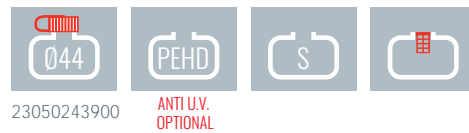

TYP	NUM.	V			PART NUMBER
G1	1	12/24	A	-	2321050
G1	1	12/24	A	●	2321083
H3	1	12/24	A	-	2321049
GS	1	12/24	A	-	2321051
GS	1	12/24	A	●	2321052
G1	2	12/24	B	-	2322051
G1	2	12/24	B	●	2322062
GS	2	12/24	B	-	2322063
GS	2	12/24	B	●	2322060

FOR COMPLETE PART NUMBER SEE PAGE 6

2.2 L

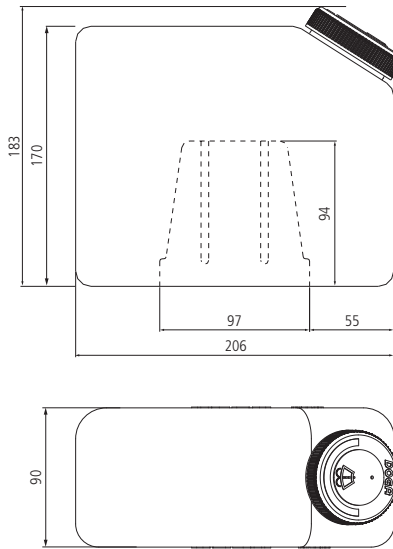
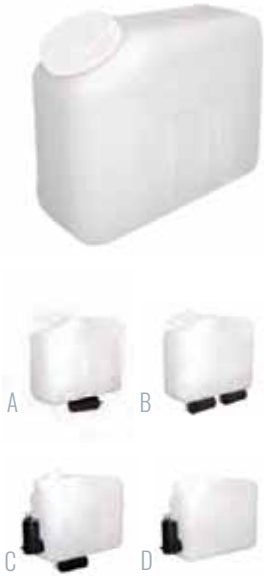

TYP	NUM.	V			PART NUMBER
D2	1	12/24	D	-	2321021
D2	1	12/24	A	-	2321046
D2	1	12/24	A	-	2321070
D2	2	12/24	C	-	2322010
D2	2	12/24	B	-	2322015

FOR COMPLETE PART NUMBER SEE PAGE 6

2.5 L

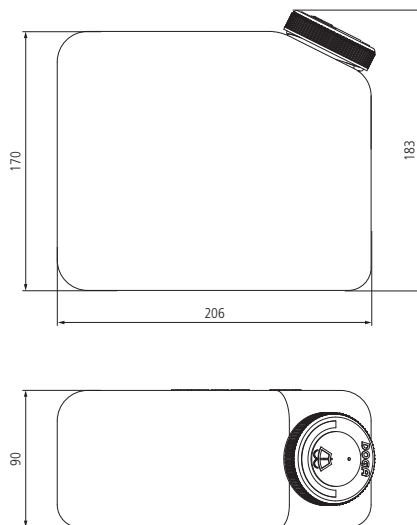

TYP	NUM.	V			PART NUMBER
D2	1	12/24	A	-	2321073

FOR COMPLETE PART NUMBER SEE PAGE 6

3 L



23000123900

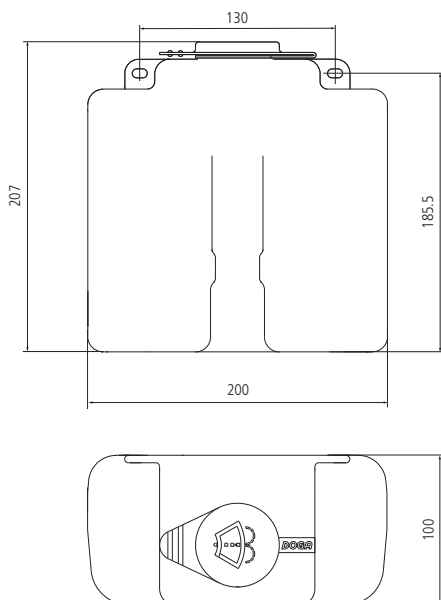

TYP	NUM.	V			PART NUMBER
G1	1	12/24	A	-	2331072
G1	1	12/24	A	●	2331073
H3	1	12/24	A	-	2331051
H3	1	12/24	A	●	2331076
GS	1	12/24	A	-	2331074
GS	1	12/24	A	●	2331075
HS	1	12/24	A	-	2331077
HS	1	12/24	A	●	2331078

FOR COMPLETE PART NUMBER SEE PAGE 6

3 L



23000123900

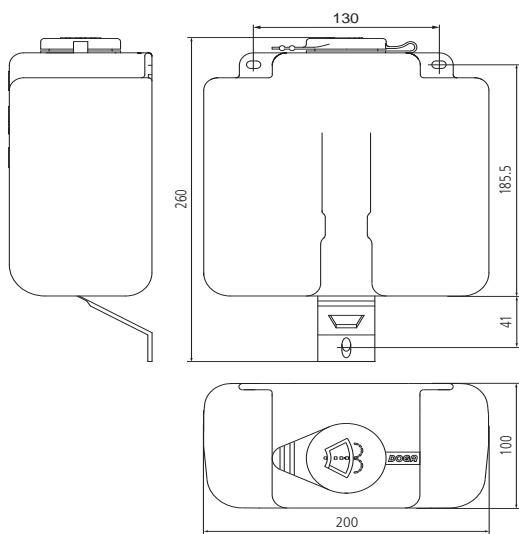

TYP	NUM.	V			PART NUMBER
G1	1	12/24	A	-	2331079
G1	1	12/24	A	●	2331080
H3	1	12/24	A	-	2331052
H3	1	12/24	A	●	2331083
GS	1	12/24	A	-	2331081
GS	1	12/24	A	●	2331082
HS	1	12/24	A	-	2331084
HS	1	12/24	A	●	2331085

FOR COMPLETE PART NUMBER SEE PAGE 6

3 L



23050243900

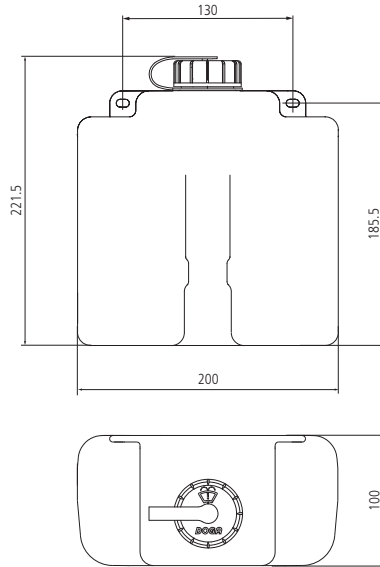

TYP	NUM.	V			PART NUMBER
G1	1	12/24	A	-	2331050
G1	1	12/24	A	●	2331038
H3	1	12/24	A	-	2331045
H3	1	12/24	A	●	2331064
GS	1	12/24	A	-	2331062
GS	1	12/24	A	●	2331063
HS	1	12/24	A	-	2331065
HS	1	12/24	A	●	2331068

FOR COMPLETE PART NUMBER SEE PAGE 6

3 L



23050243900

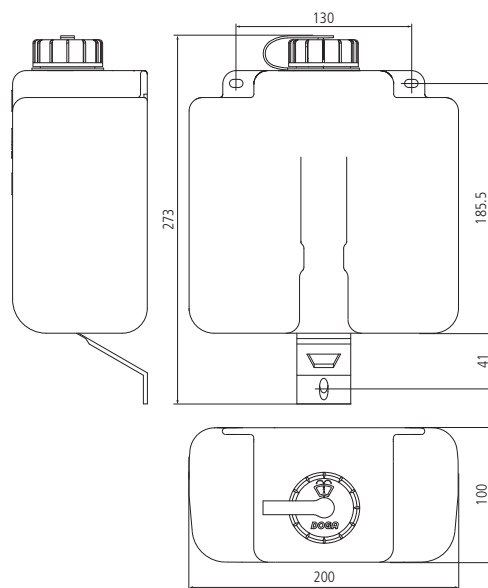

TYP	NUM.	V			PART NUMBER
G1	1	12/24	A	-	2331040
G1	1	12/24	A	●	2331039
H3	1	12/24	A	-	2331046
H3	1	12/24	A	●	2331047
GS	1	12/24	A	-	2331069
GS	1	12/24	A	●	2331070
HS	1	12/24	A	-	2331066
HS	1	12/24	A	●	2331071

FOR COMPLETE PART NUMBER SEE PAGE 6

3 L

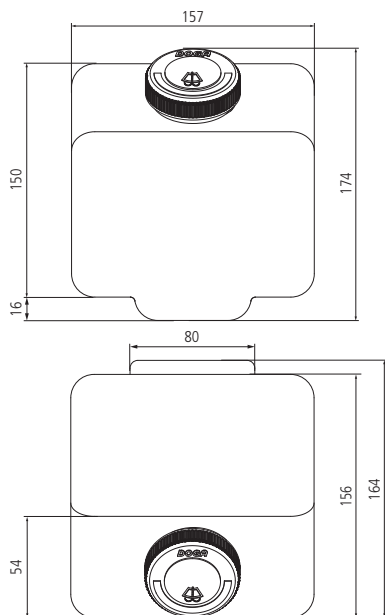
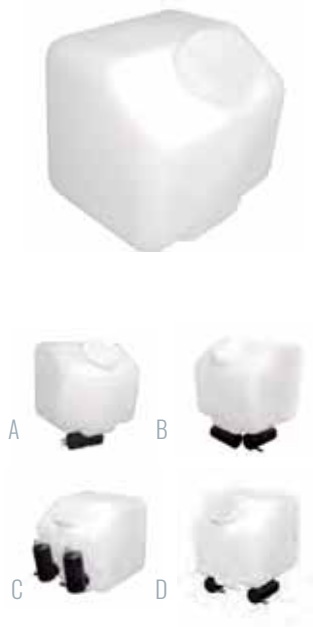

TYP	NUM.	V			PART NUMBER
D2	1	24	A	-	2331018
D2	1	24	A	-	2331021
D2	2	12/24	C	-	2332003
D2	2	12	D	-	2332022
D2	2	12	B	-	2332025

FOR COMPLETE PART NUMBER SEE PAGE 6

3.2 L

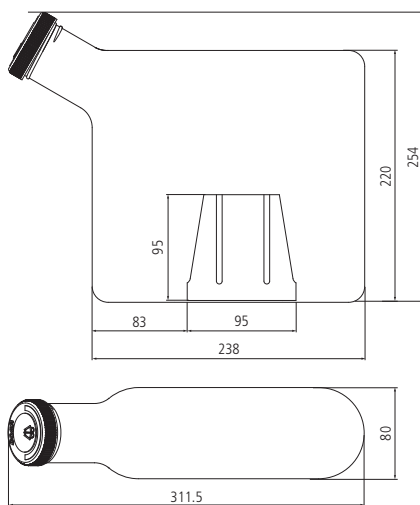
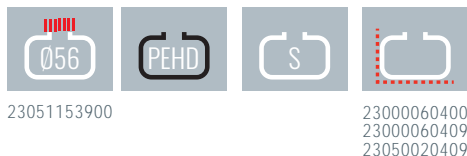

TYP	NUM.	V			PART NUMBER
D2	1	12	E	-	2331034
D2	1	24	E	-	2331040
D2	1	12/24	A	-	2331054
D2	2	12/24	B	-	2332005
D2	3	12/24	C	-	2333000
D2	4	12/24	D	-	2334000

FOR COMPLETE PART NUMBER SEE PAGE 6

3.5 L

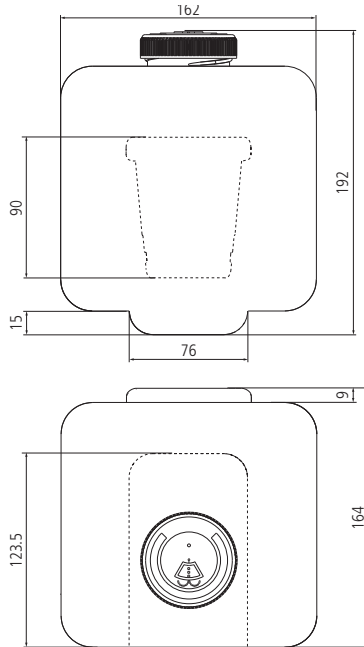

TYP	NUM.	V			PART NUMBER
D2	1	12/24	A	-	2331005
D2	1	12/24	B	-	2331055
D2	2	12/24	C	-	2332026

FOR COMPLETE PART NUMBER SEE PAGE 6

3.5 L

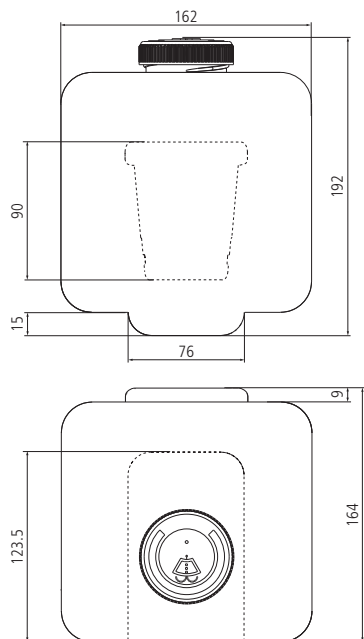

TYP	NUM.	V			PART NUMBER
D2	1	12/24	A	-	2331010

FOR COMPLETE PART NUMBER SEE PAGE 6

4 L



23050243900

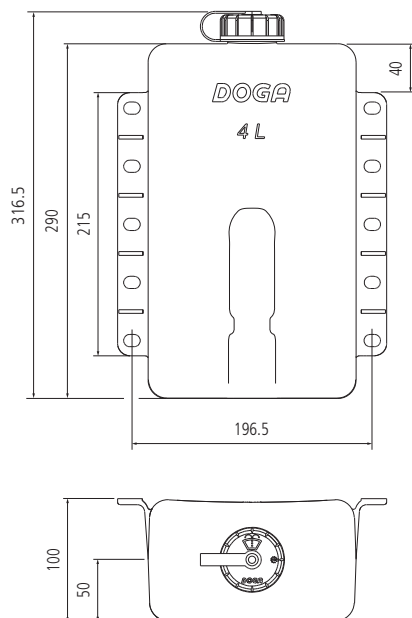

TYP	NUM.	V			PART NUMBER
G1	1	12/24	A	-	2341013
GS	1	12/24	A	-	2341014

FOR COMPLETE PART NUMBER SEE PAGE 6

5 L



23051153900 ANTI U.V.

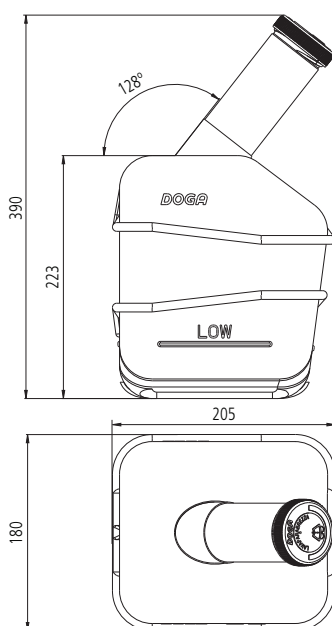

TYP	NUM.	V			PART NUMBER
D2	3	12/24	A	-	2353014

FOR COMPLETE PART NUMBER SEE PAGE 6

5 L

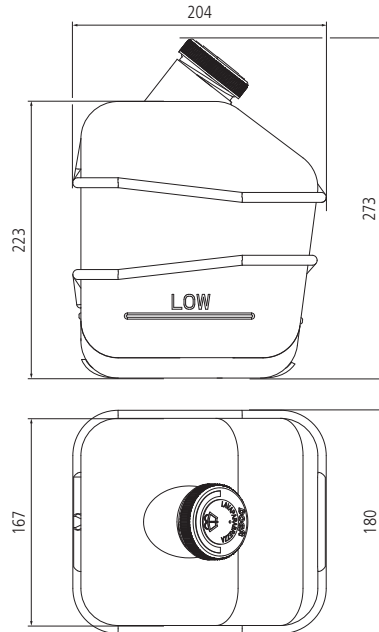

TYP	NUM.	V			PART NUMBER
D2	1	12/24	A	-	2351021
D2	1	12/24	A	•	2351062
D2	2	12/24	B	-	2352011

FOR COMPLETE PART NUMBER SEE PAGE 6

5.3 L

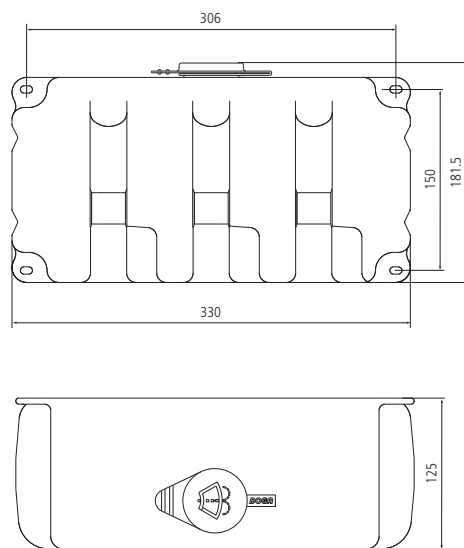

TYP	NUM.	V			PART NUMBER
G1	1	12/24	A	-	2351001
G1	1	12/24	A	•	2351002
H3	1	12/24	A	-	2351006
H3	1	12/24	A	•	2351007
GS	1	12/24	A	-	2351081
GS	1	12/24	A	•	2351082
G1	2	12/24	C	-	2352001
G1	2	12/24	B	•	2352002
GS	2	12/24	C	-	2352018
GS	2	12/24	B	•	2352019
G1	3	12/24	D	-	2353001
GS	3	12/24	D	-	2353030

FOR COMPLETE PART NUMBER SEE PAGE 6

5.3 L

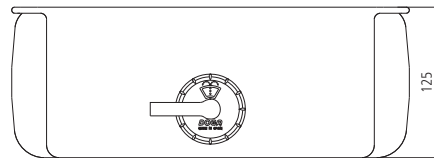
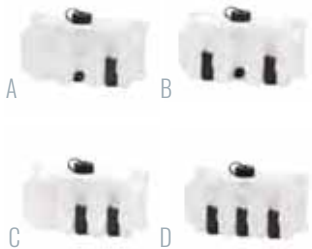
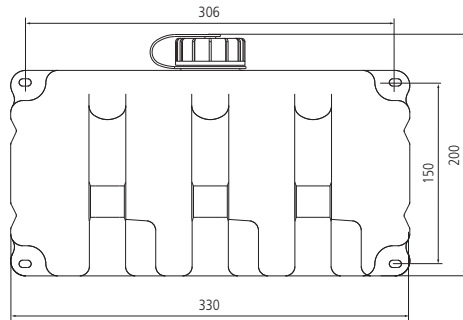

TYP	NUM.	V			PART NUMBER
G1	1	12/24	A	-	2351003
G1	1	12/24	A	●	2351004
GS	1	12/24	A	-	2351076
GS	1	12/24	A	●	2351077
G1	2	12/24	C	-	2352003
G1	2	12/24	B	●	2352004
GS	2	12/24	C	-	2352016
GS	2	12/24	B	●	2352017
H3	2	12/24	C	-	2352034
G1	3	12/24	D	-	2353003
GS	3	12/24	D	-	2353029

FOR COMPLETE PART NUMBER SEE PAGE 6

5.8 L

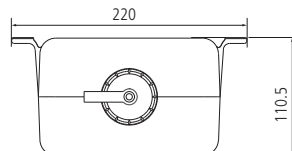
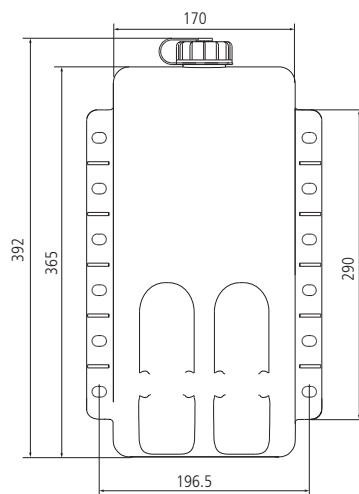

TYP	NUM.	V			PART NUMBER
G1	1	12/24	A	-	2351078
G1	1	12/24	A	●	2351079
G1	1	12/24	B	-	2351084
G1	1	12/24	B	●	2351085
GS	1	12/24	A	-	2351087
GS	1	12/24	A	●	2351080
GS	1	12/24	B	-	2351086
GS	1	12/24	B	●	2351088
G1	2	12/24	C	-	2352020
G1	2	12/24	C	●	2352021
GS	2	12/24	C	-	2352022
GS	2	12/24	C	●	2352061

FOR COMPLETE PART NUMBER SEE PAGE 6

5.8 L



23050243900

ANTI U.V.

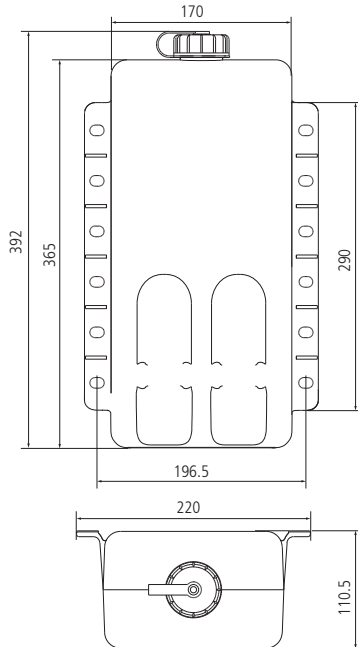

TYP	NUM.	V			PART NUMBER
G1	1	12/24	A	●	2351048
GS	1	12/24	A	●	2351083

FOR COMPLETE PART NUMBER SEE PAGE 6

7 L



41050033900

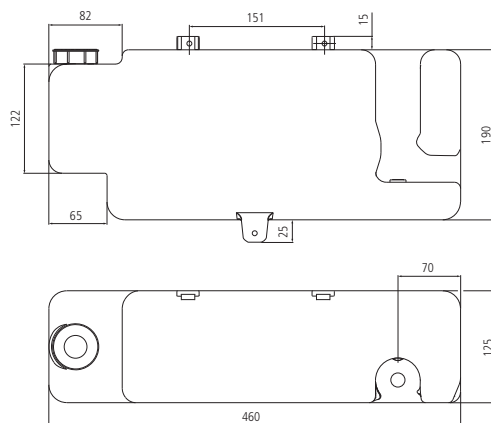

TYP	NUM.	V			PART NUMBER
F1	1	12/24	A	-	2371003

FOR COMPLETE PART NUMBER SEE PAGE 6

8.7 L



23050243900

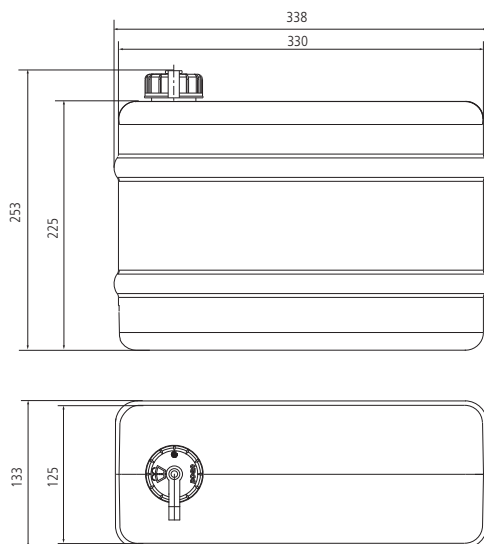

TYP	NUM.	V			PART NUMBER
G1	1	24	A	●	2381029
FOR COMPLETE PART NUMBER SEE PAGE 6					

8.7 L



23050243900

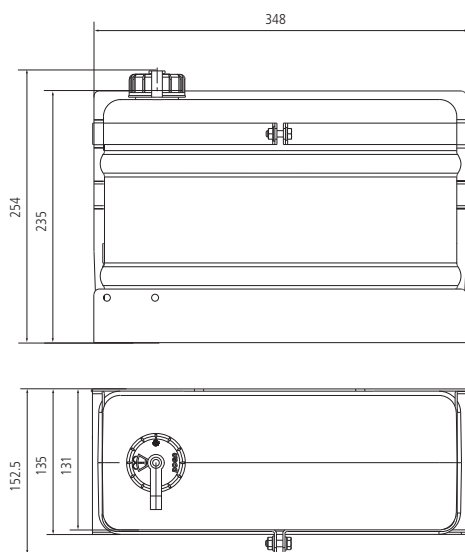

TYP	NUM.	V			PART NUMBER
G1	2	24	A	●	2305157
FOR COMPLETE PART NUMBER SEE PAGE 6					

8.7 L



23051613900

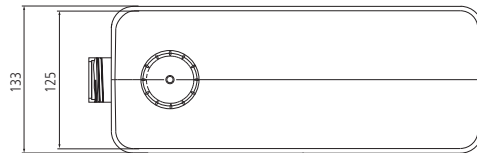
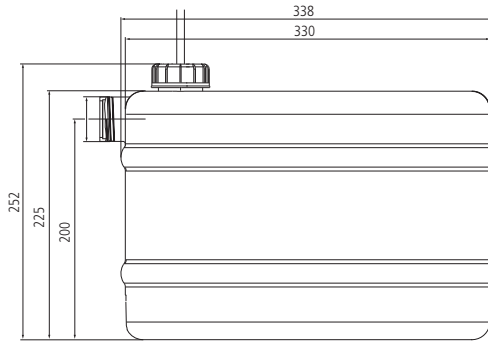

TYP	NUM.	V			PART NUMBER
GS	1	24	A	●	2382039
GS	1	24	A	●	2382040

FOR COMPLETE PART NUMBER SEE PAGE 6

9.7 L



23000123900

ANTI U.V.
OPTIONAL

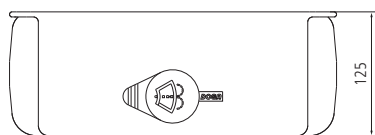
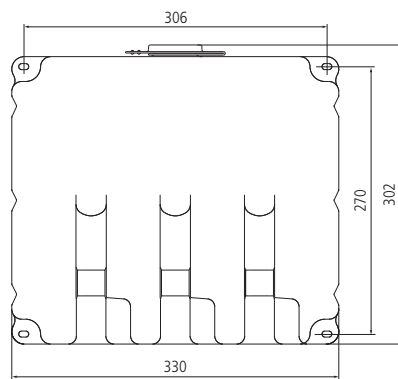

TYP	NUM.	V			PART NUMBER
G1	1	12/24	A	-	2381044
G1	1	12/24	A	●	2381045
G1	1	12/24	E	-	2381048
H3	1	12/24	A	-	2381031
H3	1	12/24	A	●	2381032
GS	1	12/24	A	-	2381046
GS	1	12/24	A	●	2381047
G1	1	12/24	E	-	2381049
G1	2	12/24	C	-	2382037
G1	2	12/24	B	●	2382028
GS	2	12/24	C	-	2382038
GS	2	12/24	B	●	2382034
G1	3	12/24	D	-	2383015
GS	3	12/24	D	-	2383016

FOR COMPLETE PART NUMBER SEE PAGE 6

9.7 L

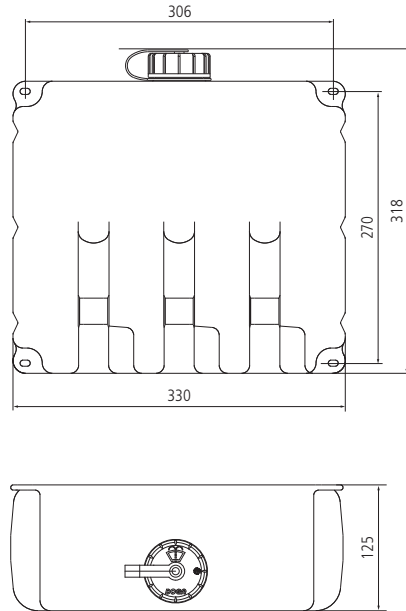
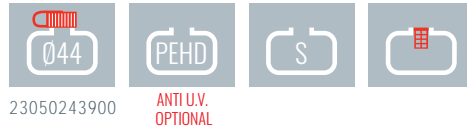

TYP	NUM.	V			PART NUMBER
G1	1	12/24	A	-	2381039
G1	1	12/24	A	•	2381028
G1	1	12/24	E	-	2381045
GS	1	12/24	A	-	2381040
GS	1	12/24	A	•	2381041
G1	1	12/24	E	-	2381042
GS	1	12/24	E	-	2381043
G1	2	12/24	C	-	2382035
G1	2	12/24	B	•	2382029
GS	2	12/24	C	-	2382036
GS	2	12/24	B	•	2382033
G1	3	12/24	D	-	2383013
GS	3	12/24	C	-	2383014

FOR COMPLETE PART NUMBER SEE PAGE 6

11.6 L

2x5.8

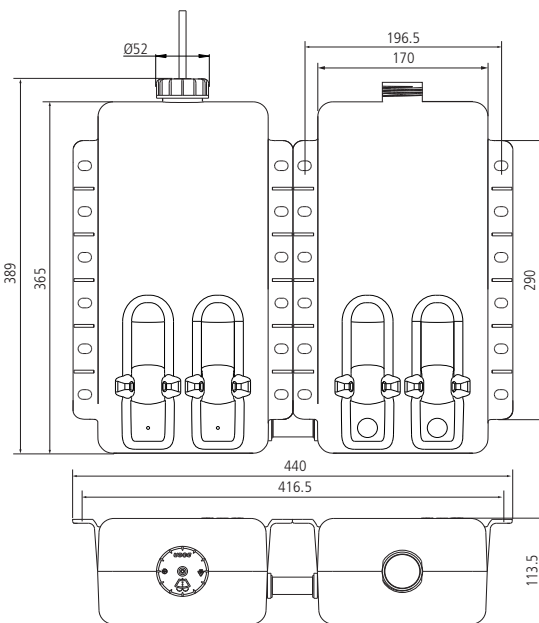
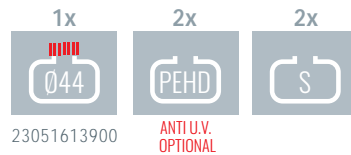

TYP	NUM.	V			PART NUMBER
GS	1	24	A	-	2305142
GS	1	24	A	•	2305143

FOR COMPLETE PART NUMBER SEE PAGE 6

15 L

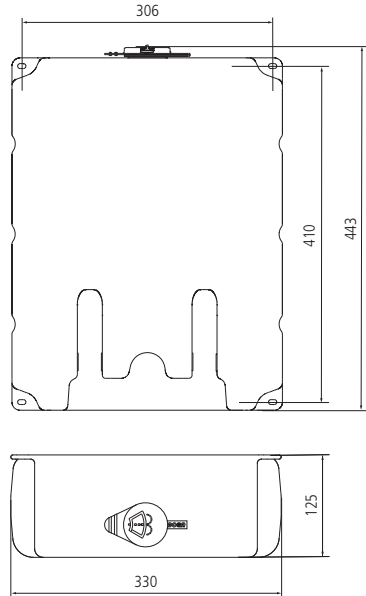
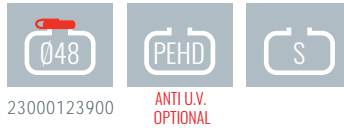

TYP	NUM.	V			PART NUMBER
G1	1	12/24	A	-	2391040
G1	1	12/24	A	●	2391041
GS	1	12/24	A	-	2391042
GS	1	12/24	A	●	2391043
G1	2	12/24	C	-	2392020
G1	2	12/24	B	●	2392036
GS	2	12/24	C	-	2392037
GS	2	12/24	B	●	2392038

FOR COMPLETE PART NUMBER SEE PAGE 6

15 L

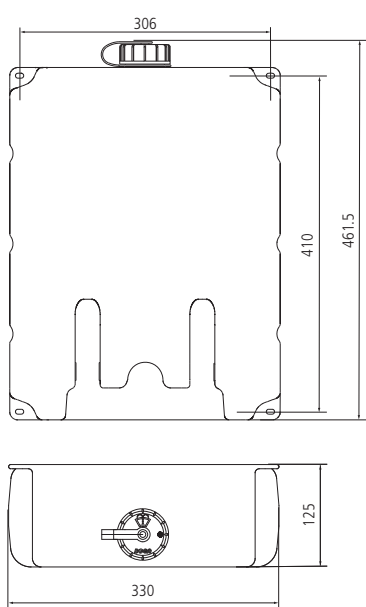

TYP	NUM.	V			PART NUMBER
G1	1	12/24	A	-	2391036
G1	1	12/24	A	●	2391037
GS	1	12/24	A	-	2391038
GS	1	12/24	A	●	2391039
G1	2	12/24	C	-	2392032
G1	2	12/24	B	●	2392033
GS	2	12/24	C	-	2392034
GS	2	12/24	B	●	2392035

FOR COMPLETE PART NUMBER SEE PAGE 6

19.4 L

2x9.7

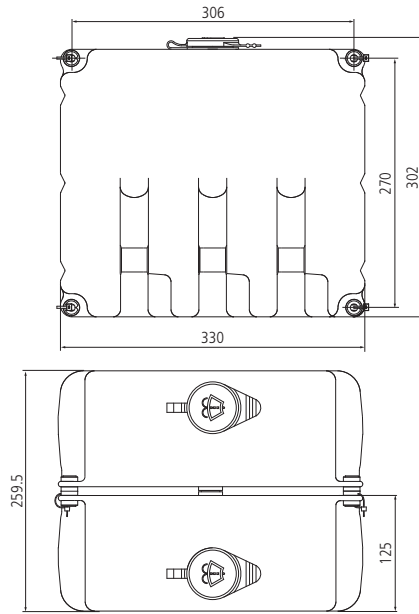
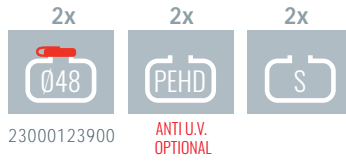

TYP	NUM.	V			PART NUMBER
G1	1	24	A	●	2305146
FOR COMPLETE PART NUMBER SEE PAGE 6					

19.4 L

2x9.7

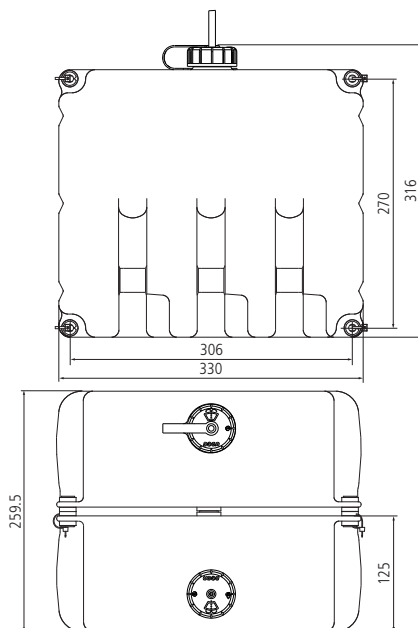
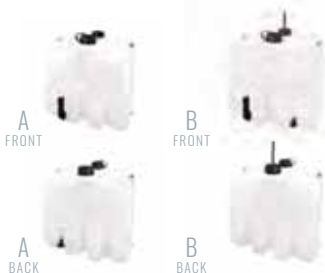
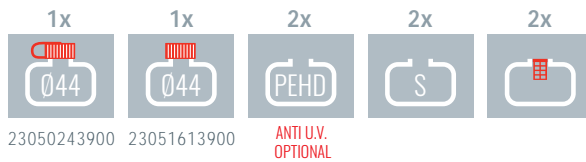

TYP	NUM.	V			PART NUMBER
G1	1	24	A	●	2305145
G1	1	24	B	●	2305066
GS	1	24	A	●	2305133
GS	1	24	B	●	2305144
FOR COMPLETE PART NUMBER SEE PAGE 6					

20 L



23050243900

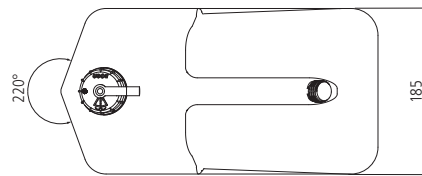
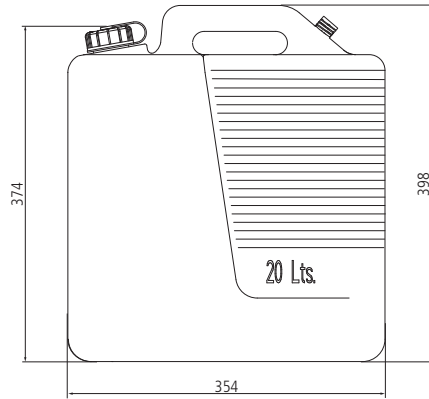

TYP	NUM.	V			PART NUMBER
GS	1	24	A	•	2391034
GS	2	24	B	•	2392031

FOR COMPLETE PART NUMBER SEE PAGE 6

WASHER PUMPS

DOGA

BOMBAS LAVAPARABRISAS - ELETTROPOMPE LAVACRISTALLI - POMPES LAVE GLACE - WASCHWASSERPUMPEN

D

GROMMET INCLUDED
JUNTA INCLUIDA
GUARNIZIONE INCLUSA
JOINT INCLUS
INKLUSIVE DICHTUNG

D2

PART NUMBER V

20100072000 12

20100073000 24

AMP 2 IP 54

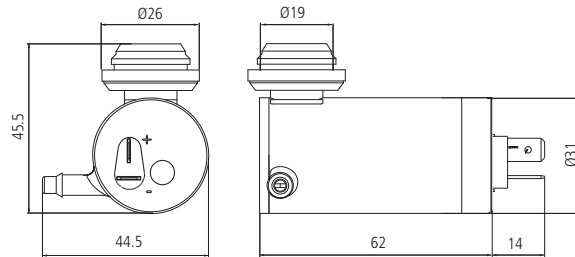

(mm)

D3

PART NUMBER V

20100402000 12

20100403000 24

SUPERSEAL 1,5 IP 54

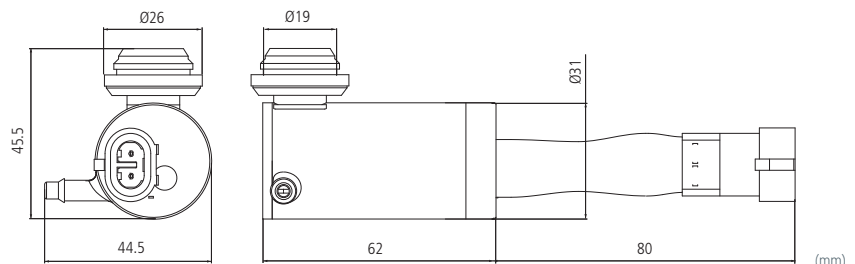

(mm)

E

GROMMET INCLUDED
JUNTA INCLUIDA
GUARNIZIONE INCLUSA
JOINT INCLUS
INKLUSIVE DICHTUNG

E1

PART NUMBER V

20100092000 12

20100093000 24

AMP 2 IP 54

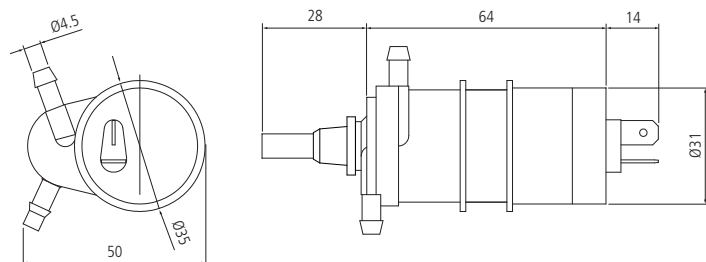

(mm)

F

GROMMET INCLUDED
JUNTA INCLUIDA
GUARNIZIONE INCLUSA
JOINT INCLUS
INKLUSIVE DICHTUNG

F1

PART NUMBER V

20100102000 12

20100103000 24

AMP 2 IP 54

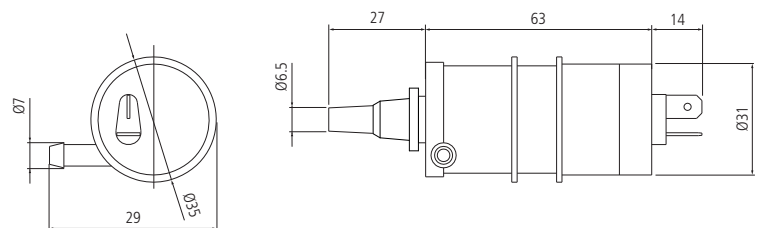

(mm)

F2

PART NUMBER V

20100502000 12

20100503000 24

DEUTSCH IP 54

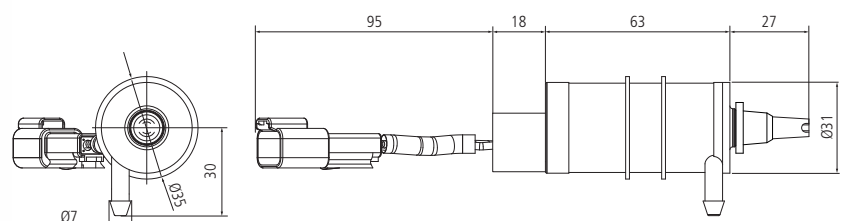

(mm)

G

GROMMET INCLUDED
JUNTA INCLUIDA
GUARNIZIONE INCLUSA
JOINT INCLUS
INKLUSIVE DICHTUNG

INTEGRATED FILTER
FILTRO INTEGRADO
FILTRO INTEGRATO
FILTRE INTEGRÉ
INTEGRIERTER FILTER

G1

PART NUMBER	V
20100832000	12
20100833000	24
AMP 2	IP 54

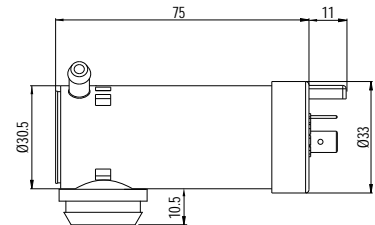
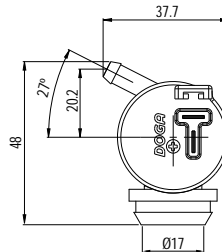

(mm)

GS

PART NUMBER	V
20101132000	12
20101133000	24
DEUTSCH	IP 67



NEW PRODUCT
IP67

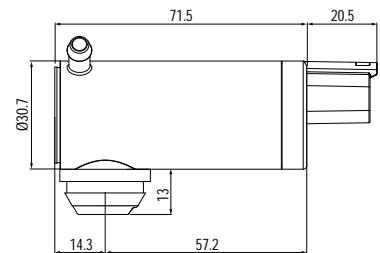
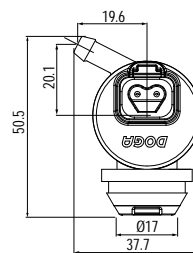

(mm)

H

H3

PART NUMBER	V
20100952000	12
20100953000	24
AMP 2	IP 54

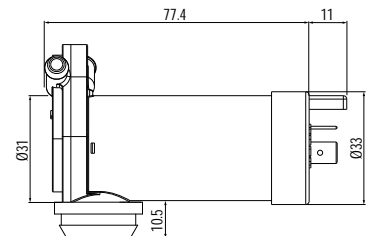
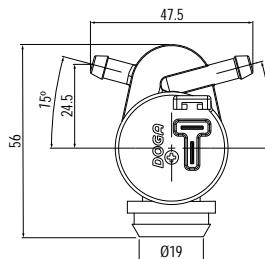

(mm)

HS

PART NUMBER	V
20101142000	12
20101143000	24
DEUTSCH	IP 67



NEW PRODUCT
IP67

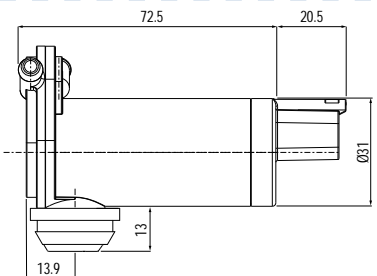
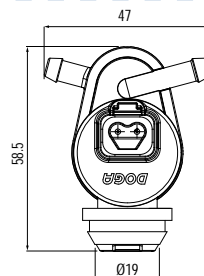

(mm)

LEVEL INDICATOR - INDICADOR DE NIVEL - INDICATORE DI LIVELLO - INDICATEUR DE NIVEAUX - FÜLLSTANDANZEIGE

PART NUMBER	V	COLOR
10050613900	12/24	●

>PA6<

AMP
superseal

IP67

GROMMET INCLUDED
JUNTA INCLUIDA
GUARNIZIONE INCLUSA
JOINT INCLUS
INKLUSIVE DICHTUNG

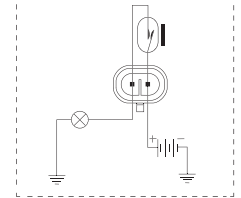
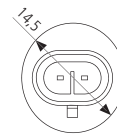
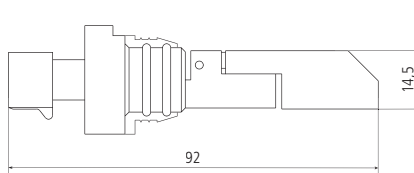

(mm)

CHECK VALVES - VÁLVULAS ANTIRRETORNO - VALVOLA DI NON RITORNO - VALVE ANTI-RETOUR - RÜCKSCHLAGVENTIL

PART NUMBER	COLOR
10051603900	●

>PA6<

⌀ 4

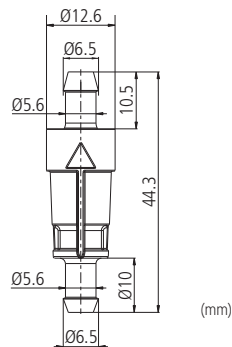

(mm)

PART NUMBER	COLOR
10050653900	●

>PA6<

⌀ 4

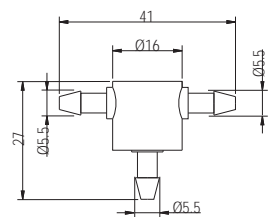

(mm)

CONNECTORS - CONECTORES - RACCORDI - CONNECTEURS - ANSCHLÜSSE

PART NUMBER	COLOR
10001063900	●
10000523900	●

>PA6<

⌀ 4

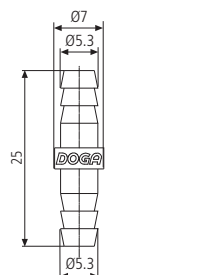

(mm)

PART NUMBER	COLOR
10000533900	●

>PA6<

1 ⌀ 3

2 ⌀ 4

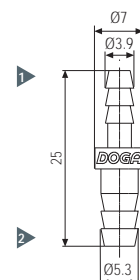

(mm)

PART NUMBER	COLOR
10000573900	●

>PA6<

⌀ 4

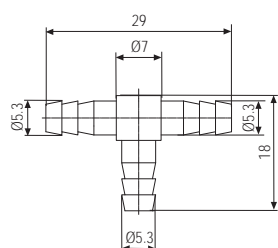

(mm)

PART NUMBER	COLOR
10000883900	●

>PA6<

1 ⌀ 3

2 ⌀ 4

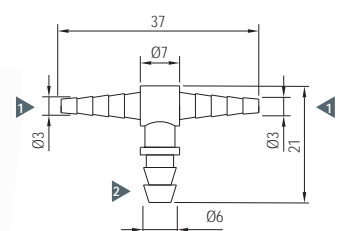

(mm)

HOSES - TUBOS - TUBI - TUBES - SCHLÄUCHE

PART NUMBER	COLOR	LENGTH
10000073900	●	1m
10000173900	●	5m
10000473900	●	100m

>EPDM<
 Ø 3

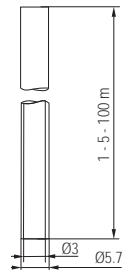

(mm)

PART NUMBER	COLOR	LENGTH
10001003900	●	1m
10001013900	●	200m

>EPDM<
 Ø 4

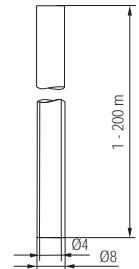

(mm)

PART NUMBER	COLOR	LENGTH
10001023900	●	1m
10001033900	●	100m

>PVC<
 Ø 4

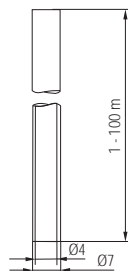

(mm)

PART NUMBER	COLOR	LENGTH
10001043900	○	1m
10001053900	○	100m

>PVC<
 Ø 4

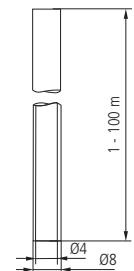

(mm)

PART NUMBER	COLOR	LENGTH
10000903900	○	1m
10000963900	○	100m

>PVC<
 Ø 3

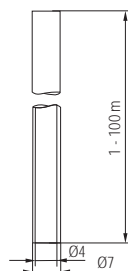

(mm)

PART NUMBER	COLOR	LENGTH
10000913900	○	1m
10000973900	○	100m

>PVC<
 Ø 3

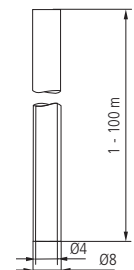

(mm)

PART NUMBER	COLOR	LENGTH
10002243900	●	100m

>PVC<
 Ø 4.5

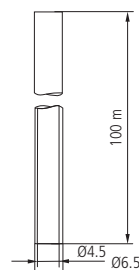

(mm)

PART NUMBER	COLOR	LENGTH
10000613900	○	1m
10000623900	○	5m

>PVC<
 Ø 4

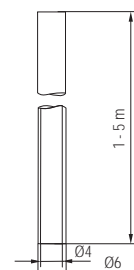

(mm)

GROMMET - PASATUBOS - PASSATUBI - PASSE-FIL - TÜLLE

PART NUMBER	COLOR
10000883900	●

>PVC<

⌀ 6 max

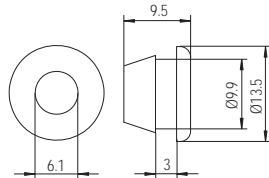

(mm)

CONNECTOR - PASAMUROS - PASSAMURI - TRAVERSÉE DE CLOISON - DURCHFÜHRUNGSTÜCK

PART NUMBER	COLOR
10050263900	●

>PA6<

⌀ 3-4

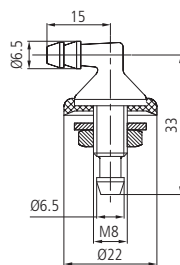

(mm)

PART NUMBER	COLOR
10050633900	●

>PA6<

⌀ 3-4

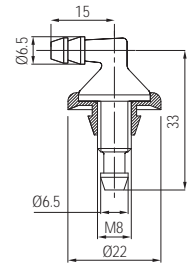

(mm)

PART NUMBER	COLOR
10050533900	●

>PA6<

⌀ 3-4

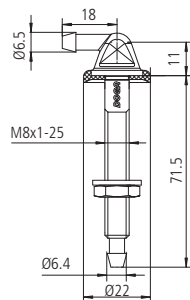

(mm)

PART NUMBER	COLOR
100551883900	●

>PA6<

⌀ 3-4

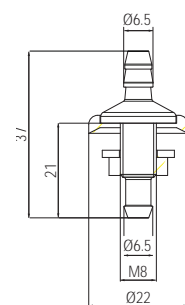

(mm)

PART NUMBER	COLOR
10051893900	●

>PA6<

⌀ 3-4

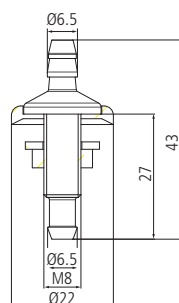

(mm)

BODY NOZZLES - SURTIDORES CARROCEÍA - SPRUZZATORI CARROZZERIA - GICLEURS CARROSSERIE - KAROSSERIE SPRITZDÜSEN

PART NUMBER	COLOR
10052793900	● SPRAY

>PA66<

⊙ Ø 3-4

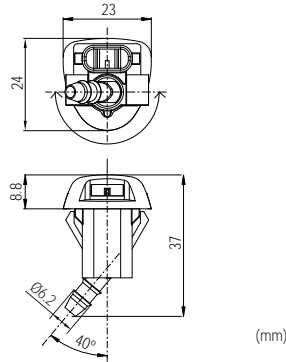
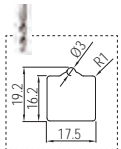

(mm)

PART NUMBER	COLOR	JETS
10050353900	●	2
10050373900	●	1

>PA6<

⊙ Ø 3-4

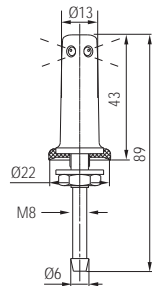
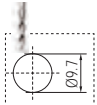

(mm)

PART NUMBER	COLOR	JETS
10050443900	●	2

>PA6<

⊙ Ø 3-4

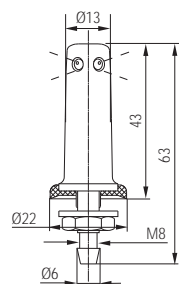
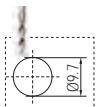

(mm)

PART NUMBER	COLOR
10051713900	● SPRAY

>PA6<

⊙ Ø 3-4

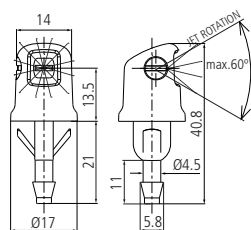
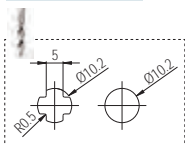

(mm)

PART NUMBER	COLOR
10051853900	● SPRAY

>PA6<

⊙ Ø 3-4

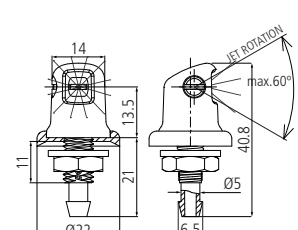
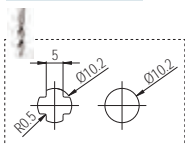

(mm)

PART NUMBER	COLOR
10052783900	● SPRAY

>PA66<

⊙ Ø 3-4

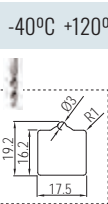

HEATED NOZZLE

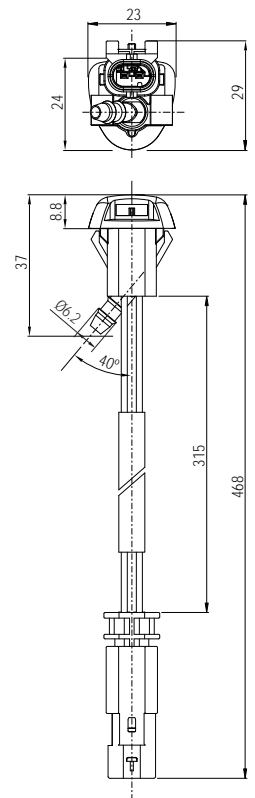

(mm)

BODY NOZZLES - SURTIDORES CARROCEÍA - SPRUZZATORI CARROZZERIA - GICLEURS CARROSSERIE - KAROSSERIE SPRITZDÜSEN

PART NUMBER	COLOR
10 051723900	● SPRAY

- >PA6<
- Ø 3-4
-

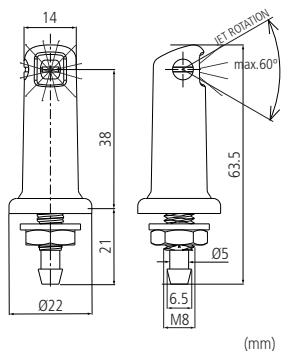
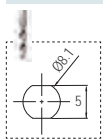

(mm)

PART NUMBER	COLOR
10051733900	● SPRAY

- >PA6<
- Ø 3-4
-

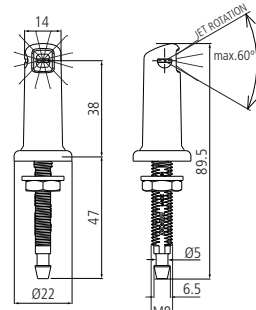
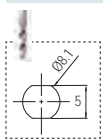

(mm)

PART NUMBER	COLOR	JETS
12150053900	●	2 (80°)

- >PA6<
- Ø 3-4
-

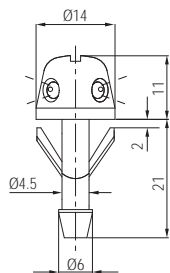
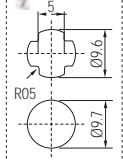

(mm)

PART NUMBER	COLOR	JETS
10050663900	●	2

- >PA6<
- Ø 4
-

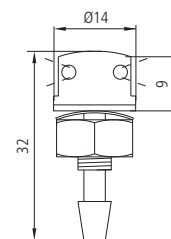
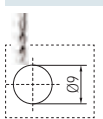

(mm)

PART NUMBER	COLOR	JETS
10050673900	●	1

- >PA6<
- Ø 4
-

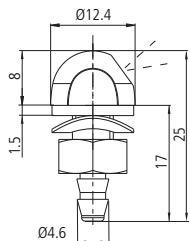
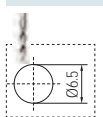

(mm)

PART NUMBER	COLOR	JETS
10050723900	●	2

- >PA6<
- Ø 4
-

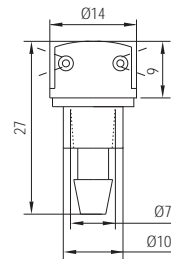
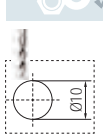

(mm)

PART NUMBER	COLOR	JETS
10050733900	●	2

- >PA6<
- Ø 3-4
-

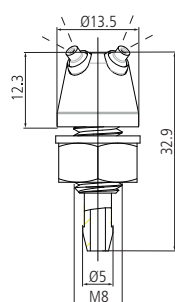
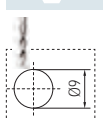

(mm)

PART NUMBER	COLOR	JETS
10050683900	●	1

- >PA6<
- Ø 3
-

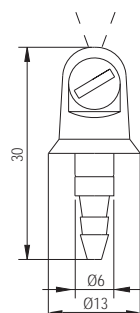
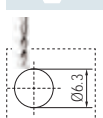

(mm)

BODY NOZZLES - SURTIDORES CARROCEÍA - SPRUZZATORI CARROZZERIA - GICLEURS CARROSSERIE - KAROSSERIE SPRITZDÜSEN

PART NUMBER	COLOR	JETS
10050693900	●	1

>PA6<

Ø 4

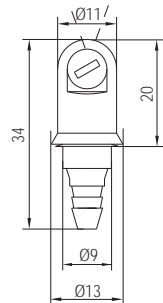
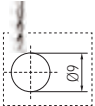

(mm)

PART NUMBER	COLOR	JETS
10050703900	●	1

>PA6<

Ø 4

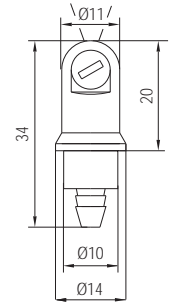
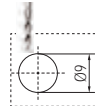

(mm)

ARM NOZZLES - SURTIDORES BRAZO - SPRUZZATORI BRACCIO - GICLEURS BRAS - SPRITZDÜSEN FÜR WISCHERARME

PART NUMBER	COLOR	JETS	STYLE
12050363900	●	2	9x3
12050403900	●	2	9x4

>PA6<

Ø 3-4

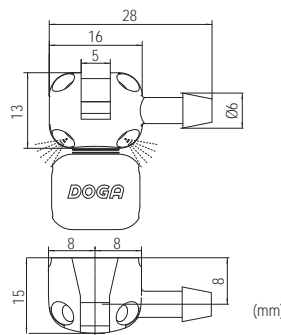

(mm)

PART NUMBER	COLOR	JETS	STYLE
12050353900	●	2	9x3
12050393900	●	2	9x4

>PA6<

Ø 3-4

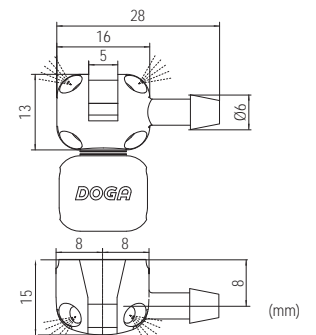

(mm)

PART NUMBER	COLOR	JETS	STYLE
12050373900	●	2	9x3
12050413900	●	2	9x4

>PA6<

Ø 3-4

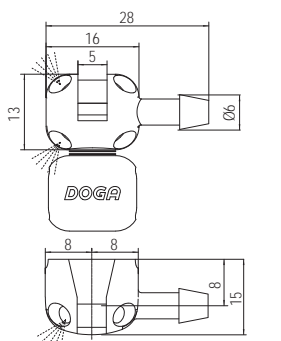

(mm)

PART NUMBER	COLOR	JETS	STYLE
12050383900	●	4	9x3
12050423900	●	4	9x4

>PA6<

Ø 3-4

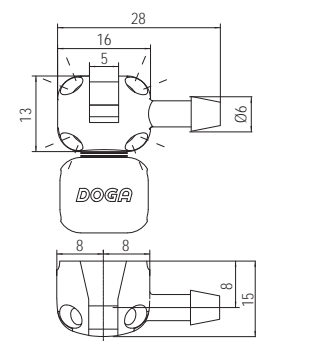

(mm)

PART NUMBER	COLOR	JETS	STYLE
12051263900	●	3	9x3
12051063900	●	3	10x4
12051083900	●	3	12x4

>PA6<

Ø 3-4

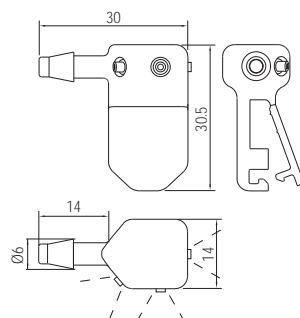

(mm)

PART NUMBER	COLOR	JETS	STYLE
12051273900	●	3	9x3
12051313900	●	3	9x4
12051073900	●	3	10x4
12051093900	●	3	12x4

>PA6<

Ø 3-4

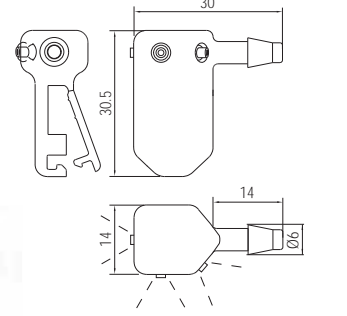

(mm)

ARM NOZZLES - SURTIDORES BRAZO - SPRUZZATORI BRACCIO - GICLEURS BRAS - SPRITZDÜSEN FÜR WISCHERARME

PART NUMBER	COLOR	JETS
12050213900	●	5

>PA6<

⊙ 03-4

2.5x15

EXCLUSIVELY FOR ARMS DOGA TYP:

127-10
127-11

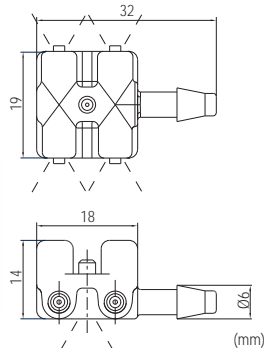

PART NUMBER	COLOR	JETS
12050203900	●	5

>PA6<

⊙ 03-4

4x15

EXCLUSIVELY FOR ARMS DOGA TYP:

127-09
127-14

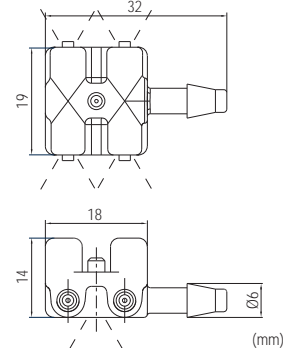

PART NUMBER	COLOR	JETS
12750163900	●	6

>PA6<

⊙ 03-4

EXCLUSIVELY FOR ARMS DOGA TYP:

127-17
128-03
128-04
128-08

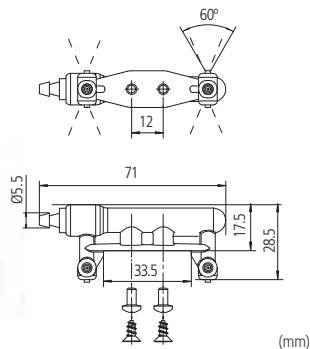

PART NUMBER	COLOR	JETS
12050303900	●	6

>PA6<

⊙ 03-4

EXCLUSIVELY FOR ARMS DOGA TYP:

120-32

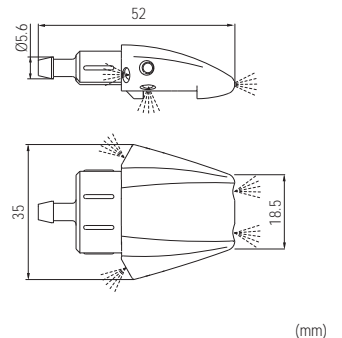

PART NUMBER	COLOR	JETS
12050053900	●	3

>PA6<

⊙ 03-4

EXCLUSIVELY FOR ARMS DOGA TYP:

120-67

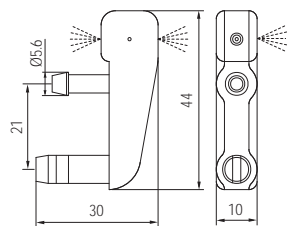

PART NUMBER	COLOR	JETS
12050253900	●	3

>PA6<

⊙ 03-4

EXCLUSIVELY FOR ARMS DOGA TYP:

120-67

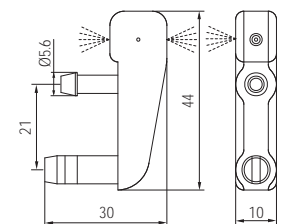

PART NUMBER	COLOR	JETS	STYLE
12001163900	●	1+SPRAY	9x3
12001173900	●	1+SPRAY	9x4
12001183900	●	1+SPRAY	10x4

>PA6<

⊙ 03-4

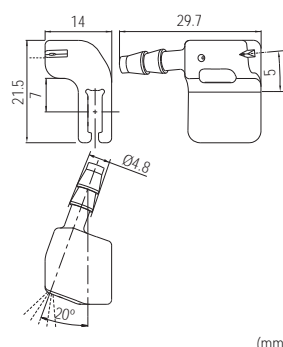

PART NUMBER	COLOR	JETS	STYLE
12001193900	●	1+SPRAY	9x3
12001203900	●	1+SPRAY	9x4
12001213900	●	1+SPRAY	10x4

>PA6<

⊙ 03-4

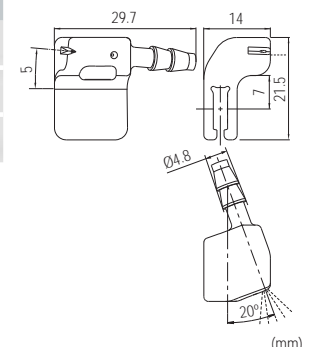

ARM NOZZLES - SURTIDORES BRAZO - SPRUZZATORI BRACCIO - GICLEURS BRAS - SPRITZDÜSEN FÜR WISCHERARME

PART NUMBER	COLOR	JETS
12050643900	●	2

>PA6<

⌀ 3-4

EXCLUSIVELY FOR ARMS DOGA TYP:

125-18

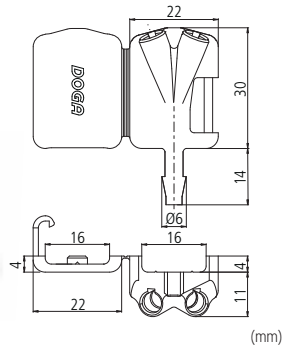

CLAMPS - BRIDAS - MORSETTI - ETRIERS DE FIXATION - CLIP

PART NUMBER	COLOR
12000623900	●

>POM<

ANTI U.V.

⌀ 6 max

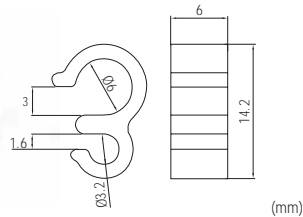

PART NUMBER	COLOR	STYLE	a x b x c
12400013900	●	8x4 - 10x4	12x18x8
12400023900	●	8x2.5 - 9x2.5	12x16.5x8
12400033900	●	9x3	13x16x10

>POM<

⌀ 6 max

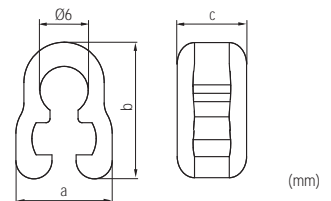

FILTER - FILTRO - FILTRE

PART NUMBER	COLOR
10002423900	●

>POM<

⌀ 40

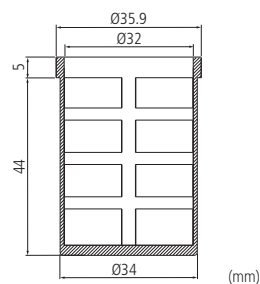

SUPPORTS - SOPORTES - STAFFE - SUPPORTS - HALTER

PART NUMBER	COLOR
23000060406	● zinc
23000060409	● zinc

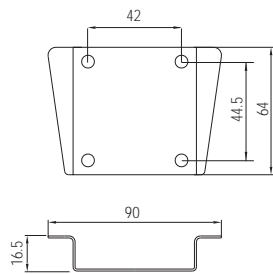

(mm)

PART NUMBER	COLOR
23050020409	● zinc

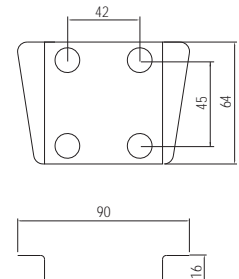

(mm)

PART NUMBER	COLOR
23000050400	● sandblast
23000050409	● zinc

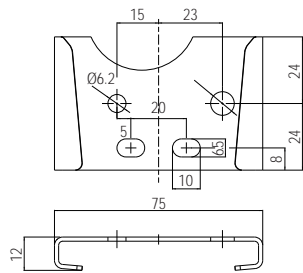

(mm)

PART NUMBER	COLOR
23000090409	● zinc

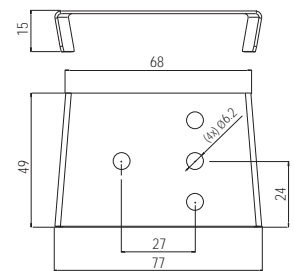

(mm)

PART NUMBER	COLOR
23000070400	● sandblast
23000070409	● zinc

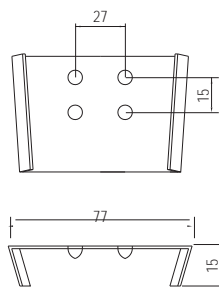

(mm)

PART NUMBER	COLOR
23000080409	● zinc

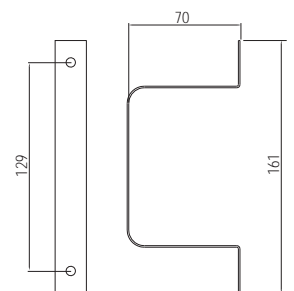

(mm)

REMOTE FILLER SPOUT - TUBO DE LLENADO - TUBO RIEMPIMENTO REMOTO - TUBE DE REMPLISSAGE - EINFÜLLSCHLAUCH

PART NUMBER	L	H
23052543900	130	215
23052553900	400	485
23052803900	500	585
23053003900	525	610
23052563900	570	655
23052753900	650	735

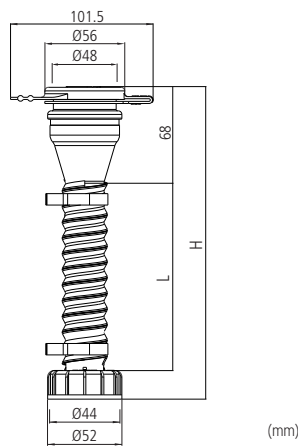
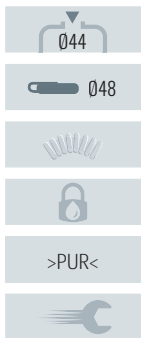

PART NUMBER	L	H
23052573900	130	215
23052583900	400	485
23052593900	570	655

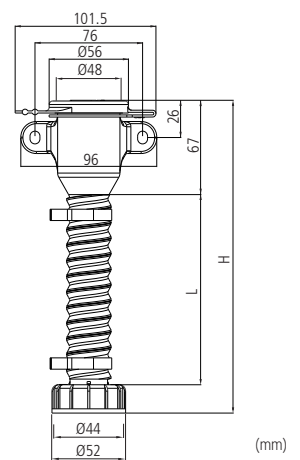
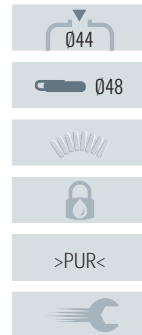

PART NUMBER	L	H
23052903900	190	285
23052603900	270	365
23052503900	360	455
23052703900	400	495
23052613900	495	590
23052523900	525	620
23052623900	610	705

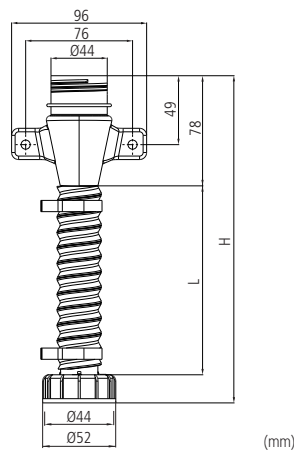
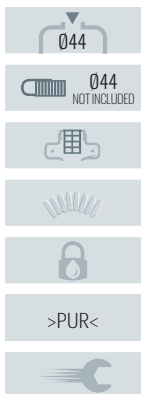

PART NUMBER	L	H
23053163900	165	270
23052773900	190	295
23052873900	210	315
23052493900	270	375
23052923900	410	515
23052633900	495	600
23052643900	610	715
23052893900	620	725
23052853900	750	855
23052483900	1750	1855

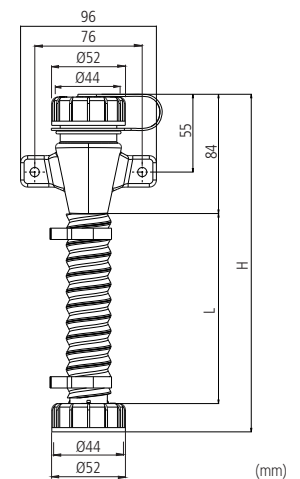
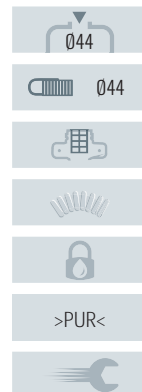

REMOTE FILLER SPOUT - TUBO DE LLENADO - TUBO RIEMPIMENTO REMOTO - TUBE DE REMPLISSAGE - EINFÜLLSCHLAUCH

PART NUMBER	L	H
23052153900	320	450
23051683900	400	530
23052123900	500	630
23051693900	600	730
23051703900	800	930
23051843900	1570	1700

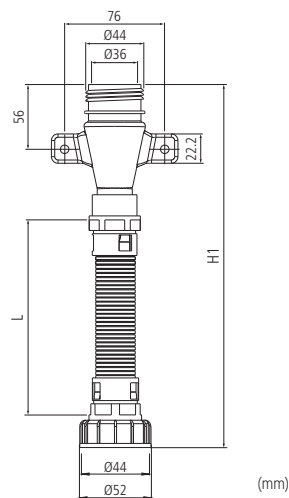

- Ø44
- Ø44 NOT INCLUDED
-
-
- >PA6<
-

PART NUMBER	L	H
23051873900	150	290
23051953900	180	320
23051643900	235	375
23051483900	400	540
23051663900	480	620
23051723900	500	640
23051493900	600	740
23051893900	665	805
23051503900	800	940
23051883900	860	1000
23052093900	870	1010
23052143900	1000	1140
23052013900	1150	1290
23051673900	1400	1540
23052003900	1750	1890
23051963900	1830	1970
23052113900	2000	2140
23052293900	2150	2290
23051973900	2500	2640
23051733900	3000	3140

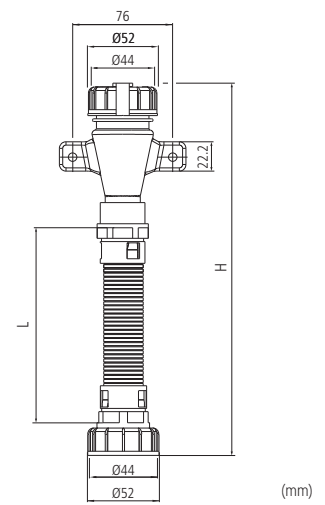

- Ø44
- Ø44 NOT INCLUDED
-
-
- >PA6<
-

MOUNTING DIAGRAM - ESQUEMA DE MONTAJE - SCHEMA DI MONTAGGIO - SCHEMA DE MONTAGE - MONTAGESCHEMA

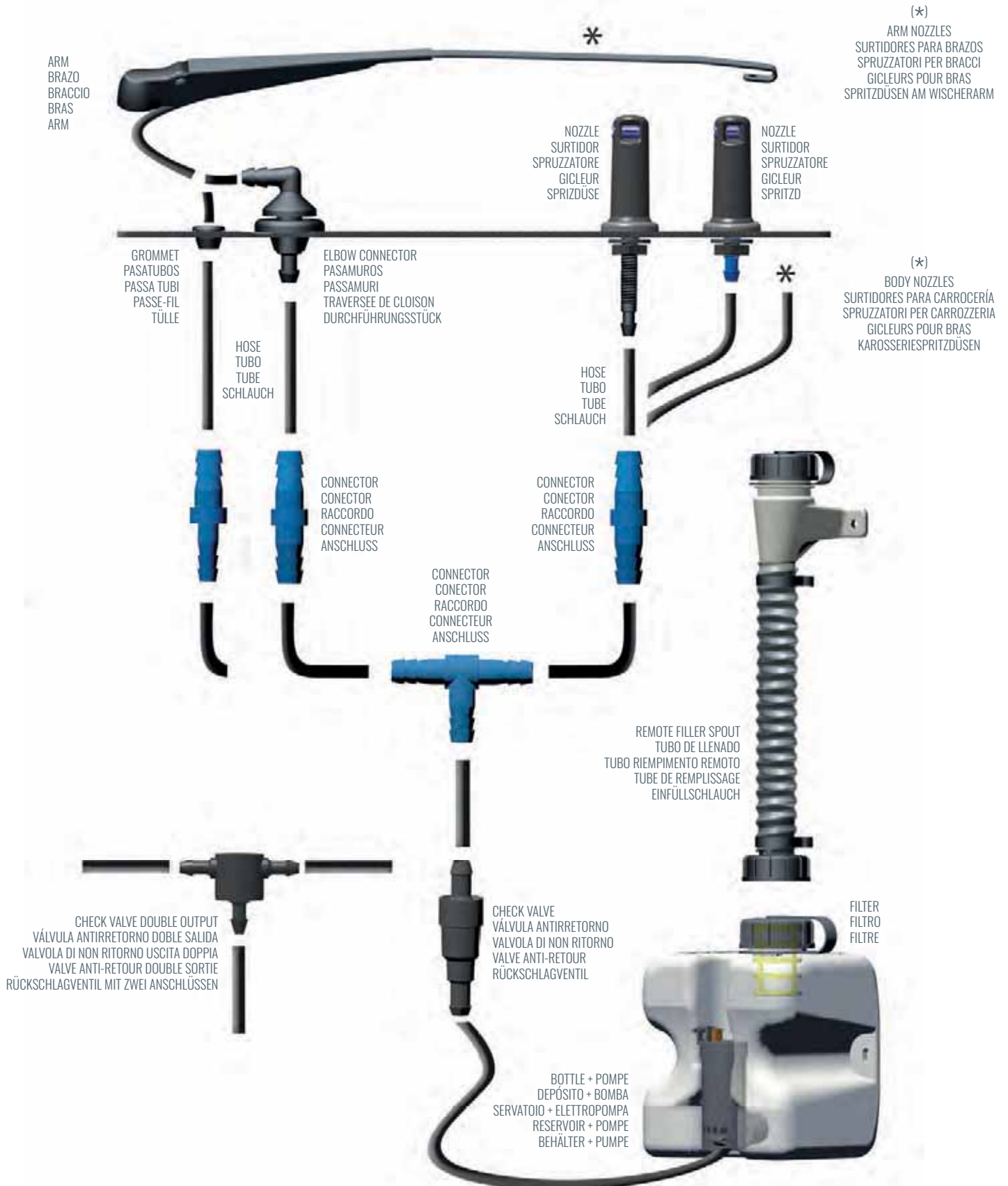

Our team of engineers turns each project into a challenge; reduced spaces, special tanks or exclusive accessories become a claim for innovating and designing windshield washer equipment that are perfectly suited for every need.

The creation of 3D prototypes, new manufacturing processes or connectivity are just a sample of the technological advances incorporated by DOGA, which translates into a functional, coherent and bespoke product design for each client.

Il nostro team di ingegneri trasforma ogni progetto in una sfida; spazi ridotti, serbatoi speciali o accessori esclusivi che diventano un richiamo per innovare e progettare attrezzature lavaparabrezza che si adattano perfettamente a ogni necessità.

La creazione di prototipi 3D, nuovi processi di fabbricazione o connettività sono solo un esempio del progresso tecnologico di DOGA, che si traduce in un design di prodotto funzionale, coerente e personalizzato per ogni cliente.

Nuestro equipo de ingenieros convierte cada proyecto en un reto y los espacios reducidos, depósitos especiales o accesorios originales se convierten en un reclamo para innovar y diseñar equipos lavaparabrisas perfectamente adecuados para cada necesidad.

La creación de prototipos 3D, mejoras en los procesos de fabricación, conectividad o análisis predictivos son solo una muestra del avance tecnológico incorporado a DOGA que se revierte en un diseño de producto funcional, coherente y personalizado para cada cliente.

Notre équipe d'ingénieurs fait de chaque projet un défi ; les espaces réduits, réservoirs spéciaux ou accessoires exclusifs deviennent une revendication pour innover et concevoir des dispositifs lave-glaces parfaitement adaptés à chaque besoin.

La création de prototypes 3D, les nouveaux processus de fabrication ou de connectivité ne sont qu'un exemple de l'avancement technologique intégré chez DOGA, qui aboutit à une conception de produit fonctionnel, cohérent et personnalisé pour chaque client.

Für unser Ingenieursteam stellt jedes Projekt eine Herausforderung dar: begrenzter Raum, besondere Behälter oder exklusives Zubehör stellen einen Anspruch an Innovation und Design von Scheibenwischeranlagen dar, die sich perfekt an jeden Bedarf anpassen.

Die Erstellung von 3D-Prototypen, neue Fertigungsprozesse oder Anschlussmöglichkeiten sind nur ein Beispiel für den technologischen Fortschritt, der bei DOGA eingeführt wurde, wodurch ein funktionelles, stimmiges und individuelles Produktdesign für jeden Kunden entsteht.



MADE-TO-MEASURE SYSTEMS - EQUIPOS A MEDIDA - PRODOTTI SU MISURA - EQUIPEMENTS SUR MESURE - BEHÄLTER NACH MASS



OPTIONAL CAPS

DOGA

TAPONES OPCIONALES - TAPPI OPZIONALI - BOUCHONS OPTIONNELS - OPTIONALE VERSCHLUSSDECKELN

WITH SEALING VALVE - CON VÁLVULA ANTIRRETORNO - CON VALVOLA ANTIPERDITA - AVEC VALVE ANTI RETOUR - MIT VASSERDICHTEN DRUCKAUSGLEICHVENTIL

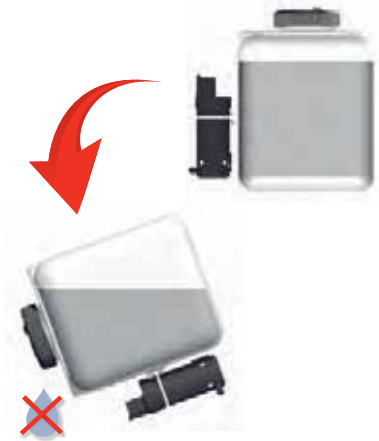

✓ PRESSURE COMPENSATION
PRESIÓN COMPENSADA
PRESSIONE COMPENSATA
PRESSION COMPENSEE
DRUCKAUSGLEICH

✓ TOTAL SEALING
ESTANQUEIDAD ABSOLUTA
TENUTA COMPLETA
ETANCHEITE ABSOLUE
ABSOLUTE DICHTHEIT

TETHERED CAP - CON BRIDA ANTIPÉRDIDA - IMPERDIBILE - AVEC ANTI-PERDU - MIT HALTERUNG



CAPS - TAPONES - TAPPI - BOUCHONS - VERSCHLUSSDECKEL

Ø	PART NUMBER					COLOR	CAPACITY										
44	23050243900	-	-	●	-	●	1.2	1.5	2.1	3	5.3	8.7	9.7	15	19.4	20	40
44	23051613900	-	●	-	-	●	8.7 ⁽¹⁾	11.6	19.4								
46	41050033900	-	●	-	-	●	7										
48	23000123900	●	-	-	-	●	1.2	2.1	3	5.3	9.7	15	19.4				
48	23000523900	●	-	-	-	●	1.2	2.1	3	5.3	9.7	15	19.4				
56	23051153900	-	●	-	-	○	1	1.1	1.5	1.75	2.2	3	3.5	5			
56	23051173900*	-	●	-	UMBRELLA	○	1	1.5	1.75	2.2	3	3.5	5				
56	23051163900	-	●	-	-	●	1.75	3.2	3.5								
56	23051223900*	-	●	-	UMBRELLA	●	1	1.5	1.75	2.2	3	3.5	5				
56	23052103900*	-	●	-	DUCKBILL	○	1	1.5	1.75	2.2	3	3.5	5				
56	23052233900*	-	-	●	UMBRELLA	●	1	1.5	1.75	2.2	3	3.5	5				

* CON ANTI REFLUJO - CON ANTIRIFLUSSO - WITH ANTI-REFLUX - AVEC ANTI-REFLUX - MIT ANTI REFLUX

(1) Ref. 23820163000



PUMPS - BOMBAS - ELETTROPOMPE - POMPES - PUMPEN

PART NUMBER			
	TYP	V	
20100522000	A1	12	AMP2
20100523000	A1	24	AMP2
20100752000	A4	12	DEUTSCH
20100753000	A4	24	DEUTSCH
20100542000	C1	12	AMP2
20100543000	C1	24	AMP2
20100912000	C2	12	DEUTSCH
20100913000	C2	24	DEUTSCH
20100082000	D1	12	AMP2
20100083000	D1	24	AMP2

SUPERSEDES STANDARD PUMPS EVOLUTION

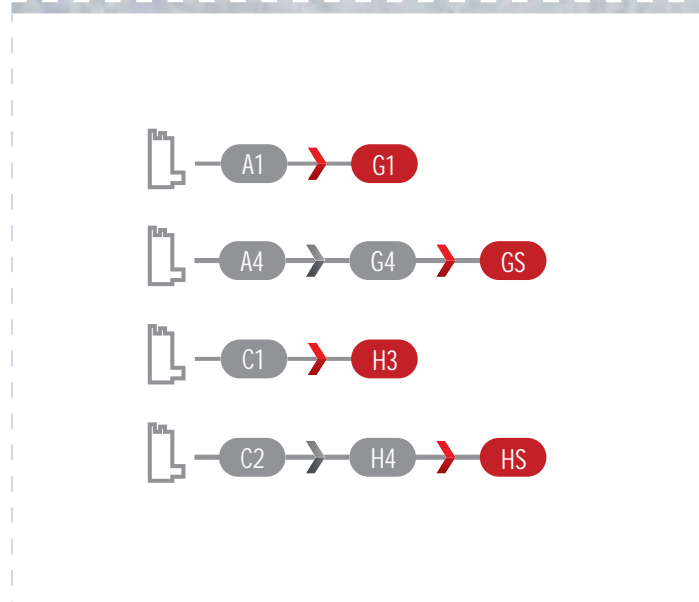

DOGA

EUROPE

DOGA, S.A. (headquarters)
Autovía A-2, Km. 583
08630 ABRERA
BARCELONA - (SPAIN)
Tel. +34 93 770 46 00
e-mail: doga@coga.es

DOGA Italia, S.R.L.
Regione Opessina, 44
14040 Castelnuovo Calcea (AT) - (ITALY)
Tel. +39 0141 963000
e-mail: dogaitalia@dogaitalia.com

DOGA Parts, S.L.U.
Avda. de la Tecnologia, 4 P.I. Can Parera
08719 CASTELLÓ
BARCELONA - (SPAIN)
Tel. +34 93 777 88 55
e-mail: info@dogaparts.es
www.dogaparts.es

AMERICA

DOGA do Brasil, Ltda.
Rua Ibaity, 111 - Vila Pernetá - Cond. Portal da Serra
83325-060 PINHAIS - PARANÁ - (BRAZIL)
Tel. +55 41 3668 1513
e-mail: dogabrasil@dogacom.br

DOGA MÉXICO COMPONENTES, SA DE C.V.
Avda. Hércules 301-C, Bodega 8
Col. Polígono Industrial Santa Rosa
Km 21 Ctra. Querétaro a San Luis Potosí
Edo. Querétaro CP 76220 - (MÉXICO)
Tel. +52 (442) 291 14 24
e-mail: comercial@dogainmesa.com

DOGA USA, Corp.
12060 Raymond Court
Huntley - IL - 60142 - (USA)
Tel. +1 847 669 8529
e-mail: dogausa@dogausa.com

ASIA

DOGA India, S.R.L.
#13, SNS Chambers 239
Sankey Road
BANGALORE 560 080 - (INDIA)
Phone 91-80-23614625 - 23615264
e-mail: dogaindia@dogaindia.com

DOGA NanTong Auto Parts Co., Ltd.
1, Xindong Road
NanTong Economic & Technology Development Area
226016 NANTONG - JIANGSU - (P.R.CHINA)
Tel. +86 513 8517 5166
e-mail: doganantong@doganantong.com

AFRICA

FAINA TANGER SARL AU
Zone Franche d'Exportation de Tanger IIlot 109, lot 3
90000 TANGER (MOROCCO)
Tel. +212 661228980



[www.doga.es]



[dogautomotive]



[doga]



[doga_it]



[dogaparts]